



USER'S MANUAL
For Shaft Alignment System VIBRO-LASER VLSAT

Contents

1.	WARRANTY	4
2.	SOFTWARE LICENSE	5
3.	PURPOSE OF THE VIBRO-LASER SYSTEM.....	8
4.	PRINCIPLE OF WORK.....	9
5.	PRECAUTIONARY MEASURES.....	9
6.	LITHIUM-ION BATTERIES.....	10
7.	RULES FOR HANDLING WITH SOURCES OF LASER RADIATION	10
8.	CHARGING MEASURING UNITS	10
9.	EQUIPMENT CARE	10
10.	WHAT IN CASE	11
11.	DESCRIPTION OF MEASURING UNITS M and S.....	11
11.1.	Description of measuring units	11
11.2.	Technical Specifications.....	12
12.	MEASURING UNITS INDICATION.....	12
13.	PREPARING THE SYSTEM FOR WORK.....	14
14.	START THE VIBRO-LASER APP	15
15.	LICENSING	16
16.	SETTINGS.....	17
16.1.	Connecting measuring units wirelessly	17
16.2.	Filters settings	19
16.3.	Choosing a system resolution limit	20
16.4.	Choosing measurement system	21
16.5.	System language.....	21
17.	INDICATIONS OF MEASURING UNITS.....	21
18.	SOFT FOOT	24
18.1.	Selection of tolerances and coupling type	24
18.2.	Distances measurement	25
18.3.	Distances measurement for machine with space shaft	25
18.4.	Distances measurement for a machine with a cardan shaft	26
18.5.	Locking Feet in the absence of the space shaft	26
18.6.	Locking feet for machines with space shaft.....	27
18.7.	Soft Foot Measurement Check.....	28
18.8.	Measurement results	29
19.	HORIZONTAL ALIGNMENT	30
19.1.	Selection of tolerances and coupling type	30

19.2.	Distances Measurement	32
19.3.	Distances measurement for machine with space shaft	32
19.4.	Distances measurement for a machine with a cardan shaft	33
19.5.	Locking Feet	34
19.6.	Locking feet for machines with space shaft.....	34
19.7.	Measurement method 9-12-3	35
19.8.	Inclinometer off measurement	36
19.9.	Multi-point method SmartPoints™	38
19.10.	Uninterrupted method SmartSpin™	39
19.11.	The cut angle method SmartAngle™	40
19.12.	SmartShift™	41
19.13.	Measurement results	42
19.14.	Results screen for space shaft machines	43
19.15.	Results screen for machines with cardan shaft.....	44
19.16.	Shims Calculator	45
19.17.	Repeatability table	46
19.18.	Indicator conversion calculator	46
19.19.	Live alignment in the vertical direction.....	48
19.20.	Live alignment in vertical direction for machines with space shaft.....	48
19.21.	Live alignment in the vertical direction for machines with cardan shaft.....	49
19.22.	Live alignment in the horizontal direction.....	49
19.23.	Live alignment without using an Inclinometer	50
19.24.	Live move mode	51
19.25.	Alignment results.....	52
19.26.	Saving reports.....	53
20.	REPORTS.....	54
20.1.	Save report as PDF file.....	54
20.2.	Adding a logo and photo to the report.....	55
21.	THERMAL GROWTH EXPANSION.....	57
21.1.	Thermal expansion corrections	57
21.2.	Intermediate feet calculator.....	60
22.	MACHINE TRAIN ALIGNMENT	63
23.	VERTICAL ALIGNMENT	66
23.1.	Selection of tolerances.....	66
23.2.	Measurement method 9-12-3	68
23.3.	Measurement results	69
23.4.	Saving reports.....	71
24.	USEFUL INFORMATION	72

24.1.	Download an application from Google Play Market and App Store	72
24.2.	Changes and additions	72

1. WARRANTY

VIBRO-LASER warrants to Buyer that the Goods (excluding any software supplied with the Goods, which Software License and Buyer's rights is set forth below in Section 6) sold hereunder will be free from defects in material and manufacture at the time of title transfer under normal use and service, provided that VIBRO-LASER's liability and Buyer's exclusive remedy under this warranty is limited to the repair or replacement, at VIBRO-LASER's election, of Goods which are shown to VIBRO-LASER's reasonable satisfaction to have been thus defective and returned to VIBRO-LASER within two (2) years after date of shipment of Goods to Buyer.

Written notice of a warranty claim must be given promptly by Buyer to VIBRO-LASER and, in no event later than sixty (60) days after Buyer's discovery of a defect within the warranty period. Transportation charges for the return of such defective Goods to VIBRO-LASER and risk of loss thereof shall be borne by Buyer. Reshipment of the newly manufactured or repaired Goods to Buyer and risk of loss thereof shall be borne by VIBRO-LASER, and are warranted for the remainder of the applicable warranty period or for ninety (90) days after shipment of the newly manufactured or repaired Good, whatever period is longer.

This warranty shall not apply to any Goods or the Goods parts in which VIBRO-LASER's sole judgment (1) have been repaired or altered outside VIBRO-LASER's facilities in any way so as to affect the safety, function or reliability of the Goods or Goods parts, or (2) has been subject to misuse, negligence, accident or other abuse. Under no circumstances shall the warranty set forth in this Section apply to any Goods which has been used with unapproved components or to any Goods, which have been customized or modified, damaged, or misused.

Third-Party-Goods (Tablets, Smartphones and other Third-Party Goods) Warranty. Notwithstanding VIBRO-LASER's warranty in above, and in lieu of such VIBRO-LASER warranty, the warranty offered by the manufacturer of any third-party manufactured goods sold or supplied by VIBRO-LASER (such as, but not limited to, a PDA, Tablet PC, Laptop, or Smartphone) is the exclusive warranty applicable to such component sold in connection with the VIBRO-LASER Goods purchased hereunder. A copy or copies of such third-party manufacturer's warranty will be furnished to Buyer upon request and/or is readily available from such third-party manufacturer and is incorporated herein by reference and is Buyer's warranty of such third-party-manufactured good.

Service Warranty for Services to Repair Goods Not Within the Warranty Period. Repair services provided by VIBRO-LASER under an Order to repair a Good which is not within the warranty period are warranted for ninety (90) days after VIBRO-LASER ships the serviced Good back to the Buyer ("Service Warranty"), provided that such Service Warranty only extends to the service VIBRO-LASER provided in such repair (including parts or components of the Good repaired or replaced in the serviced Good), and the Service Warranty shall not apply to any other part or component of the Good not submitted for service and described in the Order Confirmation to be repaired.

Exclusive Warranties and Remedies. TO THE MAXIMUM EXTENT PERMITTED BY LAW, THE FOREGOING WARRANTIES IN THIS SECTION ARE EXCLUSIVE AND ARE GIVEN AND ACCEPTED BY BUYER IN LIEU OF (i) ANY AND ALL OTHER WARRANTIES, ORAL, WRITTEN, STATUTORY, EXPRESS OR IMPLIED, INCLUDING WITHOUT LIMITATION THE IMPLIED WARRANTIES OF MERCHANTABILITY AND FITNESS FOR A PARTICULAR PURPOSE; AND (ii) ANY OBLIGATION, LIABILITY, RIGHT, CLAIM, OR REMEDY IN CONTRACT OR TORT, WHETHER OR NOT ARISING FROM VIBRO-LASER'S OR ANY OF ITS AFFILIATES' NEGLIGENCE, ACTUAL OR IMPUTED, STRICT TORT LIABILITY OR BREACH OF WARRANTY. THE REMEDIES OF THE BUYER SHALL BE LIMITED TO THOSE PROVIDED HEREIN TO THE EXCLUSION OF ANY OTHER REMEDIES INCLUDING, WITHOUT LIMITATION, INCIDENTAL, PUNITIVE AND CONSEQUENTIAL DAMAGES. NO AGREEMENT VARYING OR EXTENDING THE FOREGOING WARRANTIES, REMEDIES, OR THIS LIMITATION WILL BE BINDING UPON VIBRO-LASER OR ANY OF ITS AFFILIATES UNLESS IN WRITING, SIGNED BY A DULY AUTHORIZED OFFICER OF VIBRO-LASER OR OF SUCH AFFILIATES.

2. SOFTWARE LICENSE

VIBRO-LASER software and any third party software, documentation, interfaces, content, fonts and any data accompanying this License whether on disk, SD card, downloaded from a VIBRO-LASER-controlled website, in read-only memory, on any other media or in any other form (collectively the "VL Software") are licensed, not sold to Buyer, by VIBRO-LASER for use only under the terms of this License. VIBRO-LASER and/or VIBRO-LASER's licensors retain ownership of the VL Software itself and reserve all rights not expressly granted to Buyer.

For each computer interface purchased from VIBRO-LASER, a copy of VL Software must be purchased at the same time and are typically included with the purchase of a system or kit.

VIBRO-LASER, at its discretion, may make available future updates to the VL Software purchased. The VL Software updates, if any, may not necessarily include all existing software features or new features that VIBRO-LASER releases for newer, other or different models of VIBRO-LASER Goods. The terms of this Agreement will govern any software updates provided by VIBRO-LASER that replace and/or supplement the original VL Software for the Good(s) purchased by Buyer, unless such update is accompanied by a separate license in which case the terms of that license will govern such update.

Title and intellectual property rights in and to any content displayed by or accessed through the VL Software belongs to the respective content owner. Portions of the VL Software may utilize, include, require for installation or recommend downloading of third-party software and other copyrighted material. Acknowledgments, licensing terms and disclaimers for such material are found at such third-party software company websites, and Buyer's use of such material is governed by their respective terms. Such software is distributed or recommended by VIBRO-LASER in the hope it may be useful, but WITHOUT ANY WARRANTY BY SUPPLIER, INCLUDING BUT NOT LIMITED TO THE IMPLIED WARRANTIES OF MERCHANTABILITY AND/OR FITNESS FOR A PARTICULAR PURPOSE.

Subject to the terms and conditions of this License, Buyer is granted a limited non-exclusive license to install the VL Software purchased by Buyer on three (3) machines (tablets or laptops) owned or controlled by Buyer. Buyer may not and agrees not to, or to enable others to, copy, decompile, reverse engineer, disassemble, attempt to derive the source code of, decrypt, modify, or create derivative works of the VL Software or any services provided by the VL Software, or any part thereof. Buyer may not rent, lease, lend, sell, redistribute or sublicense the VL Software. Buyer may, however, make a one-time permanent transfer of all Buyer's License rights to the VL Software to another party, provided that: (i) the transfer must include all the VL Software, including all its component parts, original media (if any), printed materials and this License; (ii) Buyer does not retain copies of the VL Software, full or partial, including copies stored on a computer or other storage device; and (iii) the party receiving the VL Software reads and agrees to accept the terms and conditions of this License. Any copy of the VL Software that may be provided by VIBRO-LASER for promotional, evaluation, diagnostic or restorative purposes may only be used for such purposes and may not be resold or transferred. This License is effective until terminated. Buyer's rights under this License will terminate automatically or otherwise cease to be effective without notice from VIBRO-LASER if Buyer fails to comply with the term(s) of this License. Upon the termination of this License, Buyer shall cease all use of the VL Software and destroy all copies, full or parties, of the VL Software.

TO THE MAXIMUM EXTENT PERMITTED BY LAW, THE VL SOFTWARE AND THE FUNCTIONS CONTAINED IN AND/OR SERVICES PERFORMED OR PROVIDED BY SUCH VL SOFTWARE (COLLECTIVELY REFERRED TO AS "VL SOFTWARE AND SERVICES"), ARE PROVIDED "AS IS" AND "AS AVAILABLE", WITH ALL FAULT AND WITHOUT WARRANTY OF ANY KIND, AND VIBRO-LASER AND VIBRO-LASER'S LICENSORS (COLLECTIVELY REFERRED TO AS "VL") HEREBY DISCLAIM ALL WARRANTIES AND CONDITIONS WITH RESPECT TO VL SOFTWARE AND SERVICES, EITHER EXPRESS, IMPLIED OR STATUTORY, INCLUDING BUT NOT LIMITED TO, THE IMPLIED WARRANTIES AND/OR CONDITIONS OF MERCHANTABILITY, OR SATISFACTORY QUALITY, OF FITNESS FOR A PARTICULAR PURPOSE, OR ACCURACY, OF QUIET ENJOYMENT, AND NON-INFRINGEMENT OF THIRD PARTY RIGHTS.

VIBRO-LASER (VL) DOES NOT WARRANT AGAINST INTERFERENCE WITH BUYER'S ENJOYMENT OF THE VL SOFTWARE AND SERVICES, THAT THE VL SOFTWARE AND SERVICES WILL MEET BUYER'S REQUIREMENTS, THAT THE OPERATION OF THE VL SOFTWARE AND SERVICES WILL BE UNINTERRUPTED OR ERROR FREE, THAT ANY VL SOFTWARE SERVICES WILL CONTINUE TO BE MADE AVAILABLE, THAT THE VL SOFTWARE AND SERVICES WILL BE COMPATIBLE OR WORK WITH ANY THIRD PARTY SOFTWARE, APPLICATIONS OR THIRD PARTY SERVICES, OR THAT DEFECTS IN THE VL SOFTWARE AND SERVICES WILL BE CORRECTED. INSTALLATION OF VL SOFTWARE MAY AFFECT THE USABILITY OF THIRD PARTY SOFTWARE APPLICATIONS OR THIRD PARTY SERVICES.

TO THE EXTENT NOT PROHIBITED BY APPLICABLE LAW, IN NO EVENT SHALL VIBRO-LASER BE LIABLE FOR PERSONAL INJURY, PROPERTY DAMAGE, OR

ANY INCIDENTAL, SPECIAL, INDIRECT, CONSEQUENTIAL OR SIMILAR DAMAGES WHATSOEVER, WITHOUT LIMITATION, INCLUDING DAMAGES FOR LOSS OF PROFITS, CORRUPTION OR LOSS OF DATA OR INFORMATION, FAILURE TO RECEIVE OR TRANSMIT OR RECEIVE ANY DATA, BUSINESS INTERRUPTION OR ANY OTHER COMMERCIAL DAMAGES OR LOSSES, ARISING OUT OF, RELATING TO BUYER'S USE OR INABILITY TO USE THE VL SOFTWARE AND SERVICES AND/OR ANY THIRD PARTY SOFTWARE OR APPLICATIONS IN CONJUNCTION WITH THE VL SOFTWARE AND SERVICES, HOWEVER CAUSED, REGARDLESS OF THE THEORY OF LIABILITY (CONTRACT, TORT OR OTHERWISE) AND EVEN IF VIBRO-LASER HAS BEEN ADVISED OF THE POSSIBILITY OF SUCH DAMAGES. IN NO EVENT SHALL VIBRO-LASER'S TOTAL LIABILITY TO BUYER FOR ALL SUCH PROVED DAMAGES RELATING TO BUYER'S USE OF VL SOFTWARE AND SERVICES (OTHER THAN AS MAY BE REQUIRED BY APPLICABLE LAW IN CASES INVOLVING PERSONAL INJURY) EXCEED THE AMOUNT BUYER PAID SUPPLIER FOR THE VL SOFTWARE AND SERVICES. THE FOREGOING LIMITATIONS WILL APPLY EVEN IF THE ABOVE STATED REMEDY FAILS OF ITS ESSENTIAL PURPOSE.

BUYER ACKNOWLEDGES AND AGREES THAT USE OF THE VL SOFTWARE AND SERVICES IS AT BUYER'S SOLE RISK AND ENTIRE RISK AS TO SATISFACTORY QUALITY, PERFORMANCE AND ACCURACY IS WITH BUYER. BUYER ACKNOWLEDGES THAT VL SOFTWARE AND SERVICES ARE NOT INTENDED OR SUITABLE FOR USE IN SITUATIONS OR ENVIRONMENTS WHERE THE FAILURE OR TIME DELAYS OF, OR ERRORS OR INACCURACIES IN THE CONTENT, DATA OR INFORMATION PROVIDED BY, THE VL SOFTWARE AND SERVICES COULD LEAD TO DEATH, PERSONAL INJURY OR SEVERE PHYSICAL OR ENVIRONMENTAL DAMAGE, INCLUDING WITHOUT LIMITATION, THE OPERATION OF NUCLEAR FACILITIES, AIRCRAFT NAVIGATION OR COMMUNICATION SYSTEMS, AIR TRAFFIC CONTROL, LIFE SUPPORT OR WEAPONS SYSTEMS. BUYER AGREES IT MAY NOT USE OR OTHERWISE EXPORT THE VL SOFTWARE EXCEPT AS AUTHORIZED BY U.S. LAW AND LAWS OF THE JURISDICTION IN WHICH THE VL SOFTWARE WAS OBTAINED. IN PARTICULAR, BUT WITHOUT LIMITATION, THE HLI SOFTWARE MAY NOT BE EXPORTED OR REEXPORTED (A) INTO ANY U.S. EMBARGOED COUNTRIES; OR (B) TO ANYONE ON THE U.S. TREASURY DEPARTMENT'S LIST OF SPECIALLY DESIGNATED NATIONALS OR THE U.S. DEPARTMENT OF COMMERCE DENIED PERSON'S LIST OR ENTITY LIST. BUYER AGREES IT WILL NOT USE THE VL SOFTWARE FOR ANY PURPOSES PROHIBITED BY U.S. LAW, INCLUDING WITHOUT LIMITATION, THE DEVELOPMENT, DESIGN, MANUFACTURE OR PRODUCTION OF MISSILES, NUCLEAR, CHEMICAL OR BIOLOGICAL WEAPONS.

LIMITATION OF LIABILITY TO THE MAXIMUM EXTENT PERMITTED BY LAW, WITH RESPECT TO ANY VIBRO-LASER GOODS, PARTS OR SERVICES PURCHASED UNDER THIS AGREEMENT, OR, VL SOFTWARE AND SERVICES LICENSED UNDER THIS AGREEMENT, AND ALLEGED TO BE THE DIRECT OR INDIRECT CAUSE OF ANY DIRECT OR INDIRECT LOSS OR DAMAGE TO THE BUYER OR ITS CUSTOMERS, THE SUM EQUAL TO THE INVOICED PRICE OF SUCH GOODS, PARTS OR SERVICES OR LICENSE SHALL BE THE CEILING LIMIT ON VIBRO-LASER OR ANY OF ITS AFFILIATES' LIABILITY WHETHER FOUNDED IN

CONTRACT OR TORT (INCLUDING NEGLIGENCE, STRICT TORT LIABILITY OR BREACH OF WARRANTY), ARISING OUT OF OR RESULTING FROM (A) THIS AGREEMENT OR THE PERFORMANCE OR BREACH THEREOF, OR (B) THE DESIGN, MANUFACTURE, DELIVERY, SALE, LICENSE, REPAIR, REPLACEMENT, OR ANY USE OF SUCH GOODS OR VL SOFTWARE OR (C) THE FURNISHING OF ANY SUCH SERVICES. TO THE MAXIMUM EXTENT PERMITTED BY LAW, IN NO EVENT SHALL VIBRO-LASER OR ANY OF ITS AFFILIATES HAVE ANY LIABILITY TO ANY PERSON FOR INCIDENTAL, SPECIAL, CONSEQUENTIAL INDIRECT, PUNITIVE DAMAGES OR SIMILAR DAMAGES, INCLUDING LOST PROFITS, EVEN IF VIBRO-LASER HAS BEEN ADVISED OF THE POSSIBILITY OF SUCH DAMAGES. THE FOREGOING LIMITATIONS WILL APPLY EVEN IF THE ABOVE STATED REMEDY FAILS OF ITS ESSENTIAL PURPOSE.

Confidentiality: Buyer acknowledges that, under this Agreement, it will receive information not generally known to the public about the way in which VIBRO-LASER develops, designs, produces or sells its products, including the Goods, or about the way which VIBRO-LASER conducts its business including, but not limited to, information related to VIBRO-LASER's Goods, Goods needs and specifications, and VIBRO-LASER's markets, customers and sales ("VIBRO-LASER Confidential Information"). Buyer also acknowledges that the terms of specific Orders under this Agreement are VIBRO-LASER Confidential Information such care as Buyer uses in maintaining the confidentiality of its own secret information, but no less than a reasonable degree of care. Buyer will use VIBRO-LASER Confidential Information only to the extent necessary to perform its obligations under this Agreement. Buyer agrees not to analyze the composition or structure of the Goods or any other materials delivered by VIBRO-LASER to Buyer, except with VIBRO-LASER prior written consent.

VIBRO-LASER retains all its existing Intellectual Property rights (including but not limited to patents, trade secrets, know-how, trademark and copyrights) in the Goods and VL Software (and any VL Software updates). Nothing in the Order shall be construed as Buyer granting Supplier a license in or any right to use any Intellectual Property rights owned or controlled by Buyer other than as expressly contained in the Terms.

All Orders for purchase of Goods and/or Services from VIBRO-LASER will be considered New York State USA contracts and shall be interpreted for all purposes under the laws of the State of New York, without regard to: (i) New York's principles of conflicts of law; (ii) the 1980 United Nations Convention on Contracts of the International Sale of Goods; and (iii) other international laws. The parties agree to submit exclusively to the jurisdiction of both the state and federal courts of New York.

3. PURPOSE OF THE VIBRO-LASER SYSTEM

The VIBRO-LASER shaft alignment laser system is designed for precise alignment of drive driven equipment (such as electric motors) and driven equipment (such as pumps). The use of the VIBRO-LASER laser system for other purposes is not permitted and prohibited. The manufacturer is not responsible for the misuse of the VIBRO-LASER system.

4. PRINCIPLE OF WORK

The measuring units M and S includes a laser beam source and a CCD detector. The measuring units are mounted on the mating shafts (or half-couplings) opposite each other, information from the CCD detector enters the head unit and the program displays real-time information on the current values of the shaft misalignment components in the program on the display. This information is constantly updated with each movement of the machine.

5. PRECAUTIONARY MEASURES

When using the VIBRO-LASER product, observe the following precautions:

- Protect the product from rain and other water.
- Do not subject the product to shocks, jolts, strong vibrations or unnecessary pressure;
- Transport the product in a case or bag;
- Keep the product in a case or bag when you bring it in from the cold to normalize the temperature difference. Condensation of moisture inside and on the surface of the product can lead to corrosion of metal parts and electronic components. In addition, moisture accumulated inside may freeze when working with equipment in the cold. Particles of ice formed on the mechanical parts may cause equipment breakage;
- Do not use accessories from other manufacturers, this may cause the product to fail;
- It is prohibited to use undocumented features of the internal software of the product (manipulation of the engineering menu, installation of non-standard software, software changes) that have become known from unofficial sources of the manufacturer (Internet resources, periodicals). As a result of unskilled manipulations with internal software, the product's performance or the accuracy of its various systems may be irretrievably lost;
- Responsibility for backing up all data before sending the product for warranty and/or non-warranty repairs rests with the owner;
- Warranty service does not include data recovery, the manufacturer is not responsible for loss or damage to data during transportation and repair.

6. LITHIUM-ION BATTERIES

Lithium-ion batteries inevitably lose their power during their service life, depending on the ambient temperature and charging cycles. In this regard, a warranty on batteries does not apply. VIBRO-LASER can guarantee that within 1 year the capacity of the batteries will not fall below 70% after 300 charging cycles.

7. RULES FOR HANDLING WITH SOURCES OF LASER RADIATION

In the VIBRO-LASER system, laser diodes with an output power of less than 1.0 mW are used as a source of laser radiation, which meets the “Class 2” standards for SS-EN-60825-1-1994. This class is considered safe for use in devices subject to precautionary measures:

- Do not look into the laser sources when they are in operation;
- Do not direct the laser beam into the eyes of other people;
- All work requiring disassembly or repair of laser sources should be carried out only by the manufacturer.

8. CHARGING MEASURING UNITS

The power supply for the system is allowed to use a USB cable and an adapter (5V,1A). Charging the measuring units is prohibited to:

- in hazardous areas;
- in areas with high humidity and temperature;
- in the open sun;
- In areas with temperatures below 0 ° C (32 ° F).

9. EQUIPMENT CARE

- Cleaning the measuring units with a cotton cloth or a cotton swab dipped in a light soap solution. The exceptions are the surfaces of the windows of the detector and the laser, which are wiped with alcohol;
- Do not use paper towels, as they may scratch the surface of the detector window;
- Do not use substances such as acetone and / or acetone-based solvents;
- To achieve optimum performance of the product, keep the surfaces of the meter windows and connectors clean.

10. WHAT IN CASE

№	Name	Quantity, pcs
1	Measurement unit M	1
2	Measurement unit S	1
3	Chain brackets with racks 160 mm	2
4	Racks 120 mm	4
5	Extension chain with lock	2
7	USB cable	2
8	Universal Charging Adapter	1
9	Measuring Tape	1
10	Soft bag	1

11. DESCRIPTION OF MEASURING UNITS M and S

11.1. Description of measuring units

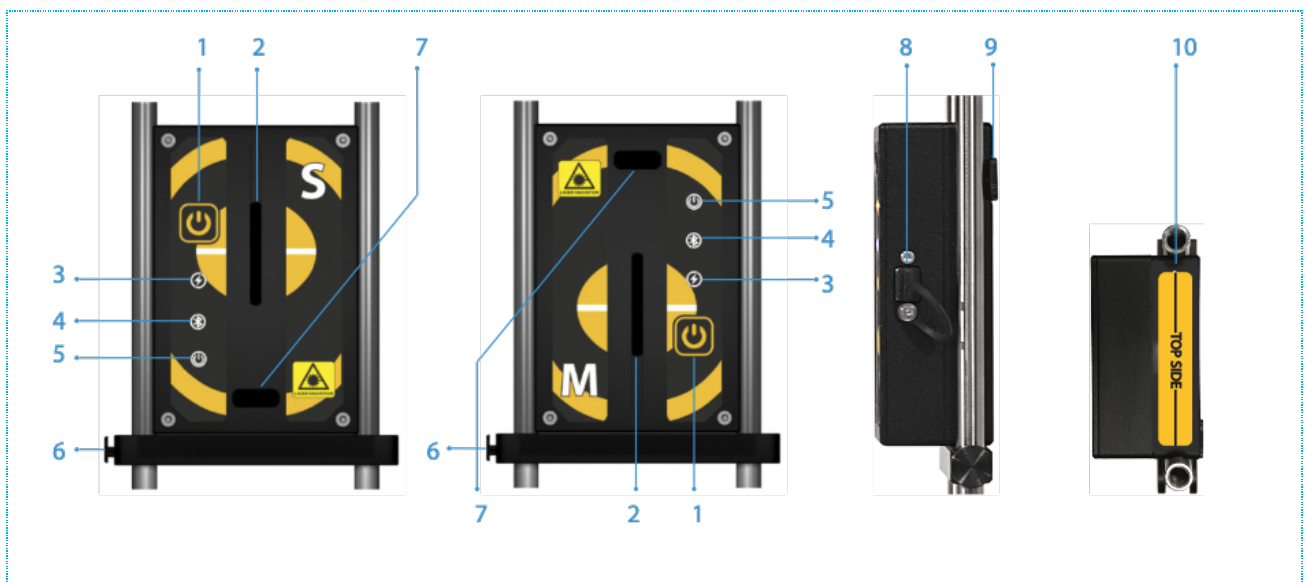

1. On / off button (to turn off, press and hold for 2-3 seconds)
2. Detector receiving window
3. Indicator of charge of measuring units
4. Communication indicator (when communication is established with a tablet or computer, it lights up in blue, flashes blue during data transfer)
5. The power indicator (lights up in red - ready to go, green - ready to take measurements)
6. Screw bar
7. Laser beam window
8. Mini USB connector (used to charge the measuring units)
9. Adjusting screw (adjusts the position of the laser beam in the vertical plane)
10. The centers of the racks of the units M and S

11.2. Technical Specifications



Material	Anodized Aluminum
Dimensions	90 MM x 60 MM x 32 MM
Laser Specifications	635nm, Class II Diode
Laser Power	<1 mw
Measuring Range	.1m – 10m
Detector Size	30 MM
Detector Type	CCD
Detector Resolution	0.001mm
Inclinometer Resolution	0.1°
Battery Life	20 hours
Communications	Bluetooth 4.0
Temperature Range	-20°C to +55°C or -4°F to +131°F
Environmental Protection	IP67 – MIL-STD810G

12. MEASURING UNITS INDICATION

When the measuring units are turned on, the indicator № 5 lights red.



Hint:

1. To turn off, press and hold  for 2-3 seconds.
2. If after pressing the power button  on the measuring units the indicator does not light up, put the measuring units in charge.

After the units have been connected to the device, the indicator №4 lights up in blue. The indicator №4 is flashing during data transfer in blue.

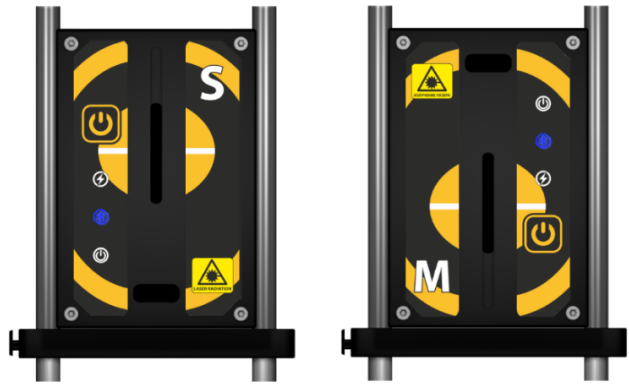

During charging of the measuring units, the indicator №3 glows green.



Hint:

When the measuring units are fully charged, the indicator will go out.

The indicator №3 glows green when the measuring units enter the green zone on the circle when measured using the 9-12-3 method or at any time when measured using the cut angle method.



13. PREPARING THE SYSTEM FOR WORK



1. Hold the mount with the draw chain vertically and install it on the shaft. Raise the free end of the chain, stretch it, removing the slack, and fasten it on the clevis.
2. Tighten the chain tightly with the tightening screw. Do not create excessive tension.
3. Place the measuring units M and S between the racks so that the screw bar is under the measuring units. It is allowed to install the screw bar above the measuring units in the case when the units M and / or S are tightly adjacent to the base of the bracket.
4. Make sure that the measuring units are tightened securely on the rack. Mounts are symmetrical and can be installed from different sides.
5. If the shaft diameter is too large, the chain length can be increased with an extension chain.
6. The measuring unit with the marking "M" is installed on the mobile machine, and the measuring unit "S" - on the stationary one. If it is not possible to install it directly on the shafts (for example, in case of limited space), the fasteners can be mounted on the coupling.
7. Install the measuring units so that the upper part of the case M is 2 cm below the upper part of the case S so that the laser line is on the receiving window of each of the measuring units. Adjust the height of the units, smoothly moving them along the uprights. Fix the position of the units with the screw on the fixing plate.

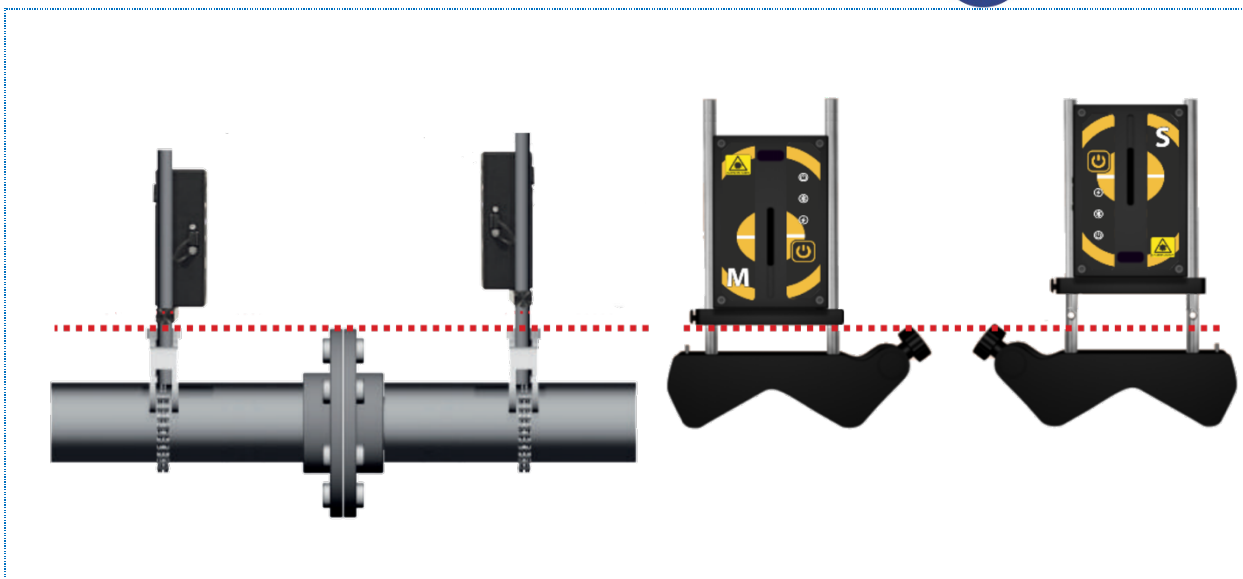

8. We recommend that, in order to improve the measurement accuracy, install the units so that the distance between them is as large as possible, ranging from 0.1 to 10 m.

14. START THE VIBRO-LASER APP

Tap the VIBRO-LASER program icon located on the desktop of your device (tablet).

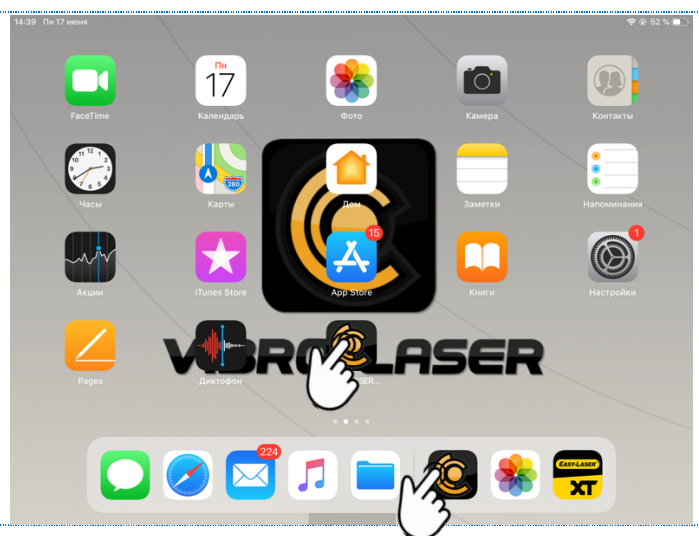

15. LICENSING

Tap the System information icon.



Tap the Key icon.

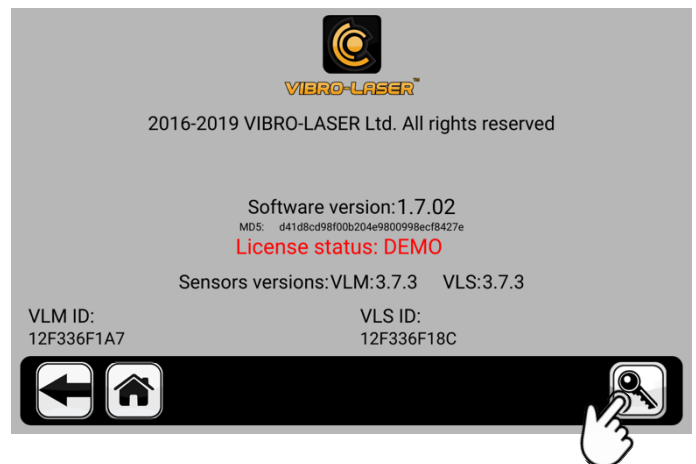

Enter the license key.

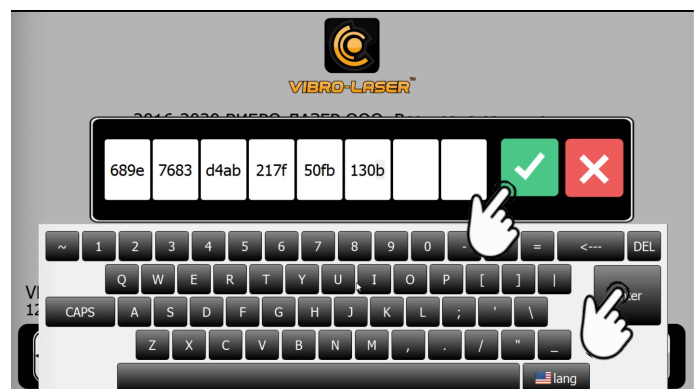

Hints:

1. In order for VLSAT to function properly it must be licensed. Any recordings taken in demo mode will result in no reading or "0";
2. In the case of using two or more sets of measuring units with one head unit (tablet), you must enter the license key of the set that you are connecting;
3. License verification occurs when the tablet is connected to the measuring units and the ID (serial numbers) of VLM and VLS are scanned;
4. To confirm the key entry - first press the "OK" or "Enter" button on the keyboard, and then tap the green icon with a check mark;

5. If everything was done correctly, the red inscription “License status: DEMO” will change to green inscription “License status: LICENSED”

16.SETTINGS

16.1. Connecting measuring units wirelessly

Tap the Global settings icon.



Tap the Search measuring heads icon.

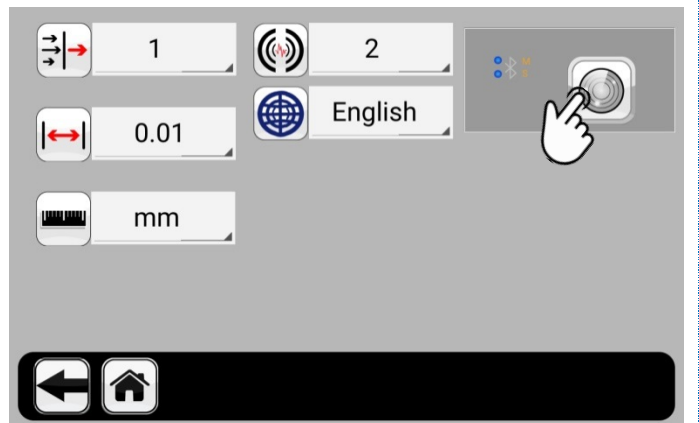

Hint:

The tablet or computer should be located next to the measuring units.

Connecting.

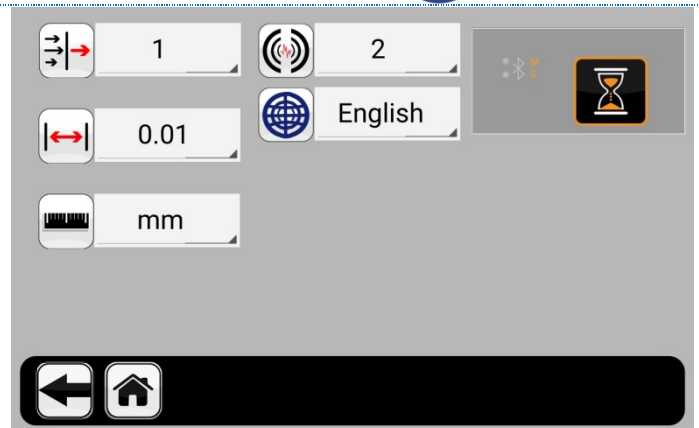

Hint:

Bluetooth connection may take some time, do not Tap the icon again until the hourglass symbol disappears. The first connection may take several minutes.

When units have connected, the lights will turn blue.

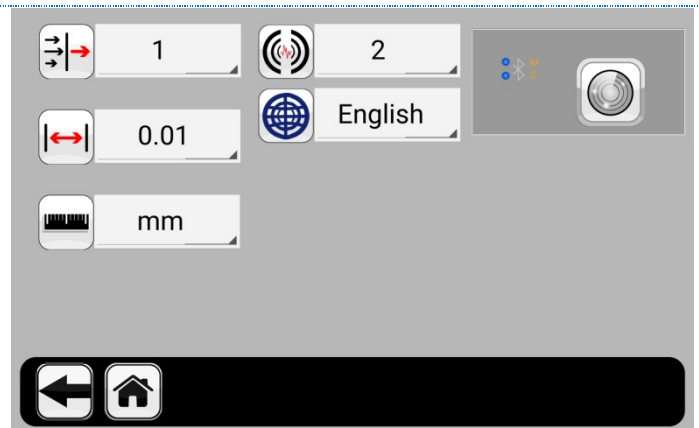

Hint:

If the connection of one or both of the measuring units did not occur, do the following:

1. Minimize or exit VIBRO-LASER by pressing the button  on the main menu screen;
2. Go to the Bluetooth settings on the device (tablet), check the Bluetooth connection, then select “VLS” and “VLM” from the list of displayed devices and establish a connection with them;
3. Go to the VIBRO-LASER Alignment application and repeat the connection of the measuring units;
4. Upon subsequent use, the measuring units will automatically connect by default.

16.2. Filters settings

There are 2 filters available to insure the most accurate results possible.

1. The optical SmartFilter™ for averaging data over the detector reduces the influence of external factors (draft, high or low temperature, lighting variation, fog, smoke, steam) during measurements.
2. VibeDr™. Filter averaging by inclinometer (angle of rotation of sensors) reduces the effect of vibration during measurements. The filter increases the stability of the rotation angle data when taking measurements under various high vibration conditions.

Select Optical Filter averaging data on the detector (averages the data obtained when the laser beam is incident on the detector).



Hint:

1. Select the data averaging filter from 1 to 16, where 1 is the minimum external influence on the operation of the measuring units (vibration, draft, high or low temperature, fog, smoke, steam), and 16 is the maximum influence of external influence;
2. If the laser beam passes through a zone with a variable temperature (air temperature in this zone, it rises, then decreases), this can affect the oscillation of the beam and lead to unstable measurements;
3. Try to reduce the intensity of air movement between the lasers and the detector (for example, by moving heat sources or closing doors). If the measurement results remain unstable, increase the value of the filter averaging data on the detector;
4. The SMART mode differs from the previous ones in that it is based on an intelligent algorithm that allows to obtain much more accurate data when measuring under external influence on the operation of measuring units.

Select Vibration Filter Averaging.

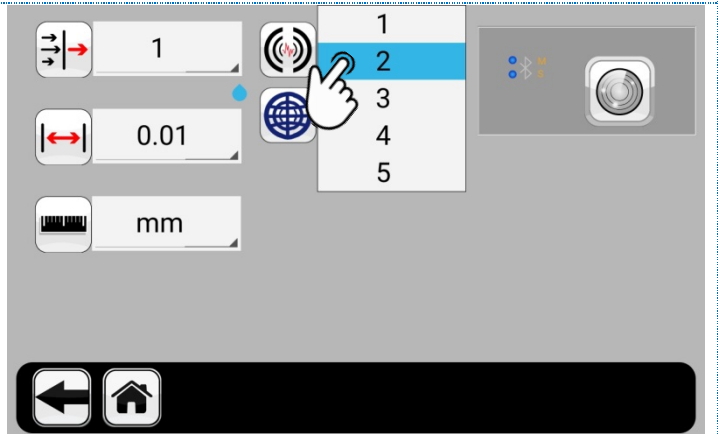

Hint:

1. This filter helps to measure in certain angles of inclination in conditions of increased vibration;
2. The user is provided with filter values from 1 to 5, where 1 is no averaging, and 5 is the maximum averaging angle.

16.3. Choosing a system resolution limit

Select the limit of accuracy of the detector data.

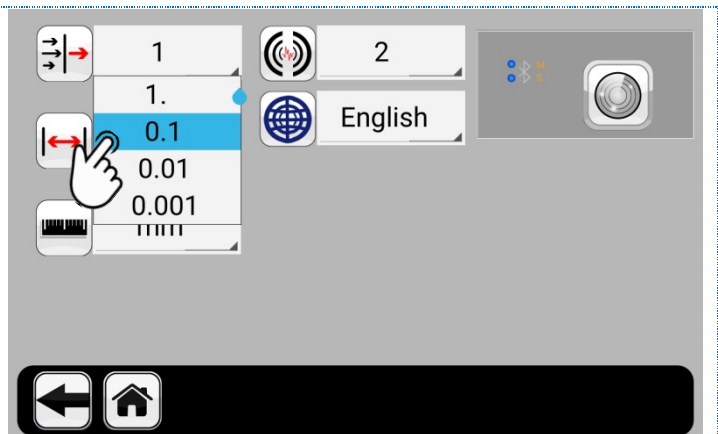

Hint:

1. If you are working in inches, use the values 1. and 0.1;
2. If you are working in mm, then use the values 0.1 to 0.001;
3. Depending on the tolerance for the misalignment of the measured unit, you can choose the required accuracy value (for example, the tolerance for the coupling alignment of 0.25 mm, respectively, you can choose a value, and the range is from 1 to 0.1)

16.4. Choosing measurement system

Select mm if working in metric measurement system or mils in the case of work in the USA measurement system.

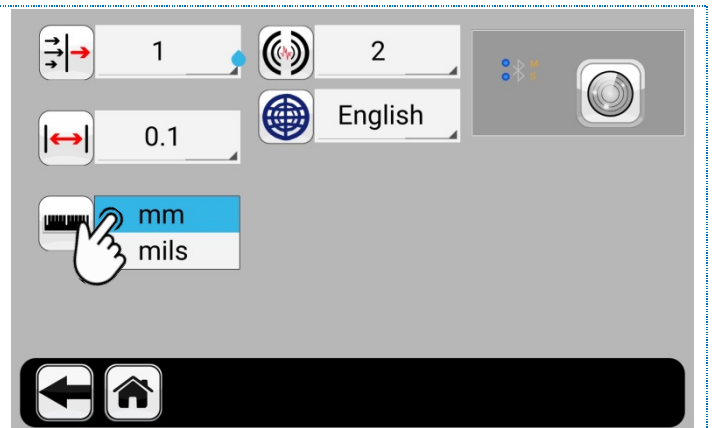

16.5. System language

Choose one of the system language and restart VIBRO-LASER application.



Hint:

1. If you do not restart the application, the selected language will not be applied.

17. INDICATIONS OF MEASURING UNITS

Tap the Measuring units readings icon.

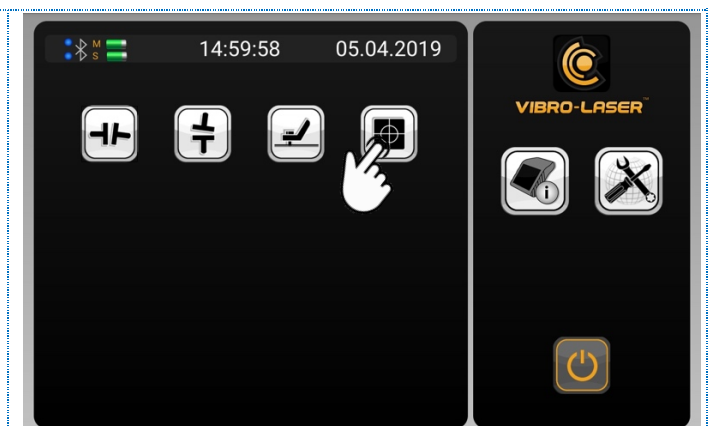

Measuring units readings.

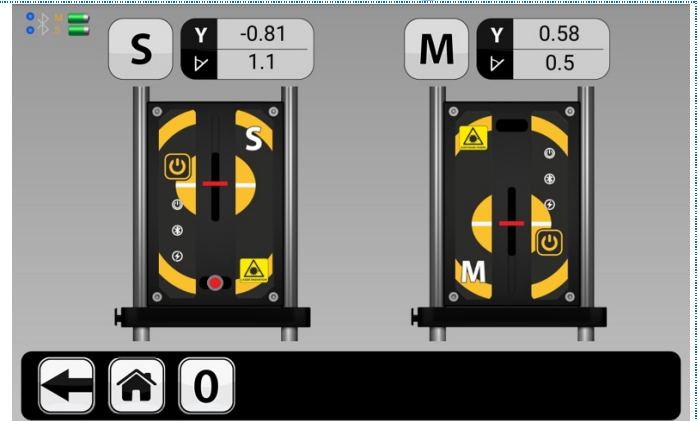

Hint:

When you open the readings of the measuring units, you can see the data coming directly from the measuring units on the screen:

1. Y - the value of the position of the laser beam on the detector;
2. The reading of the angle of rotation of the measuring units from 0 to 360 degrees (the difference in the readings of the angle of rotation of the measuring units should not exceed 1 degree, as indicated by the screen).
3. Place the measuring units so that the upper part of the case M is 2 cm below the upper part of the case S, then use the wheel on the back of the case of the measuring units to place the beam in the center of the receiving window of the detector and press the icon with the image 0 (Zero).

If values (Y) are absent, this means that the laser beam does not enter the detector area or there is an obstacle in its path. In this case, the system will not allow measurements.

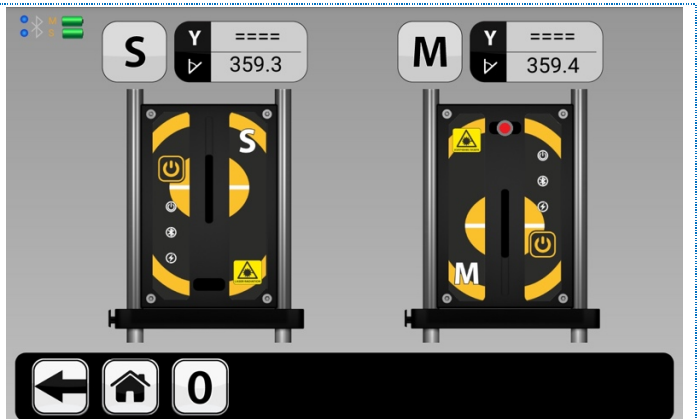

Hint:

1. The laser beam does not enter the detector area, use the adjustment screw on the back of the measuring unit housing to change the position of the laser beam on the detector, or adjust the position of the units by moving them smoothly along the racks.
2. Ensure that there are no obstacles between the laser beam and the detector.

If the (Y) values are highlighted in pink, this means that the laser beam is at the boundary of the detector's active zone

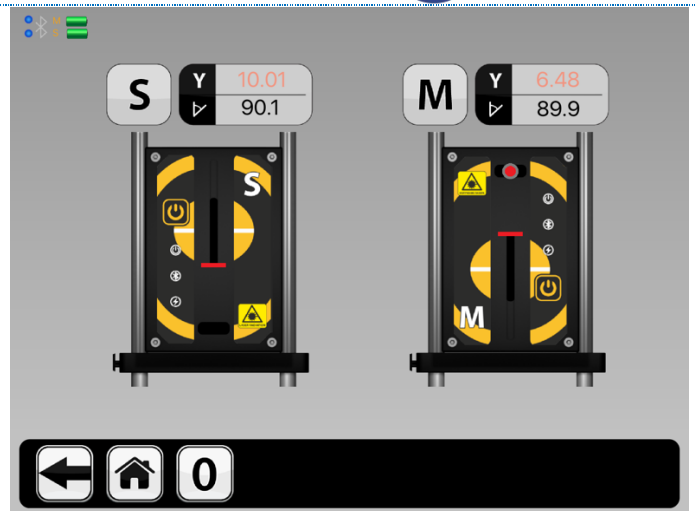

Hint:

The laser beam does not enter the detector area, use the adjustment screw on the rear of the measuring unit housing to change the position of the laser beam on the detector, or adjust the position of the units by moving them smoothly along the racks.

If the values (Y) are highlighted in red, this means that the measuring units are too close to each other. In this case, the system will not allow measurements

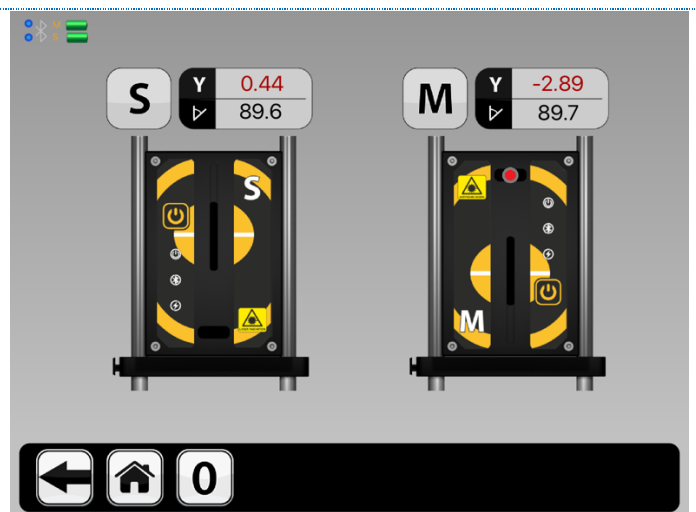

18. SOFT FOOT

18.1. Selection of tolerances and coupling type

Tap the Horizontal alignment icon.

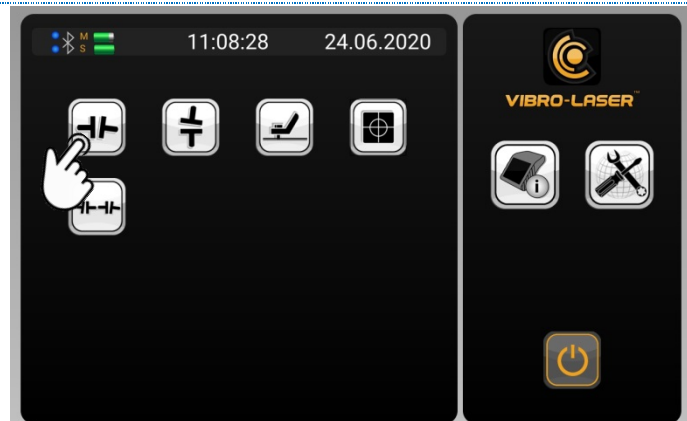

Tap the Select tolerances icon.



Select coupling type (machine):

-  Coupling;
-  Space shaft;
-  Cardan shaft.

Rpm	mm	mm / 100
0-1000	0.07	0.06
1000-2000	0.05	0.05
2000-3000	0.03	0.04
3000-4000	0.02	0.03
4000-5000	0.01	0.02
5000-6000	0.01	0.01
2000	0.2	0.2

Return to the main menu and tap the Soft foot icon

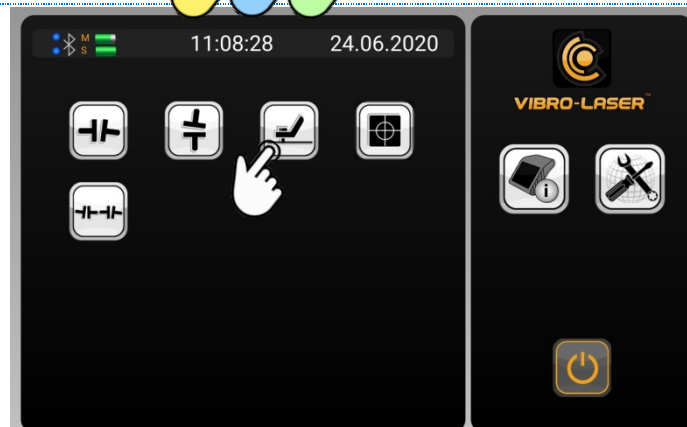

18.2. Distances measurement

Fill in the values in the windows with a “?”.

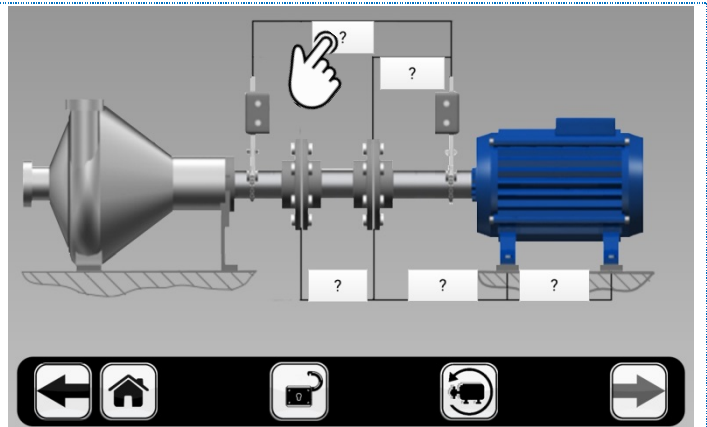

Hint:

Make sure the measuring units are at the 12 o'clock position as indicated on the screen. Use a tape measure to measure:

1. The distances between the centers of the racks of the units M and S;
2. The distance between the center of the coupling and the center of the rack unit M;
3. The distance between the center of the coupling and the first pair of feet of the moving machine;
4. The distance between the first and second pair of feet of the moving machine;
5. Go to the measurement, click on the arrow icon.

18.3. Distances measurement for machine with space shaft

Fill in the values in the windows with a “?”.

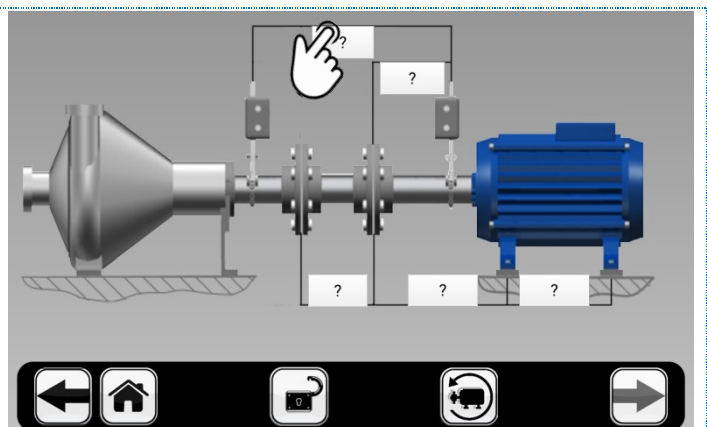

Hint:

Make sure the measuring units are at the 12 o'clock position as indicated on the screen.

Use a tape measure to measure:

1. The distances between the centers of the racks of the units M and S;
2. The distance between the center of the coupling and the center of the rack unit M;
3. The distance between the center of the coupling and the first pair of feet of the moving machine;

4. The distance between the first and second pair of feet of the moving machine;
5. Distance between the half coupling centers;
6. Go to the measurement, click on the arrow icon.

18.4. Distances measurement for a machine with a cardan shaft

Fill in the values in the windows with a “?”.

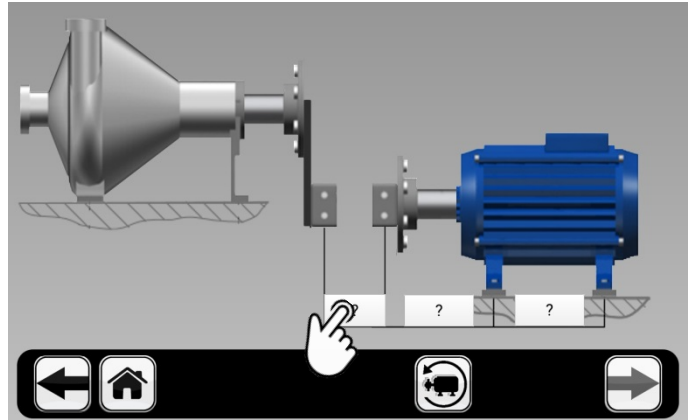

Hint:

Make sure the measuring units are at the 12 o'clock position as indicated on the screen.

Use a tape measure to measure:

1. The distances between the centers of the racks M and S;
2. The distance between the center of the rack M and the first pair of feet of the mobile machine;
3. The distance between the first and second pair of feet of the moving machine;
4. Go to the measurement, click on the arrow icon.

18.5. Locking Feet in the absence of the space shaft

Tap the Padlock icon to indicate which pairs of feet (supports) are locked in your case.

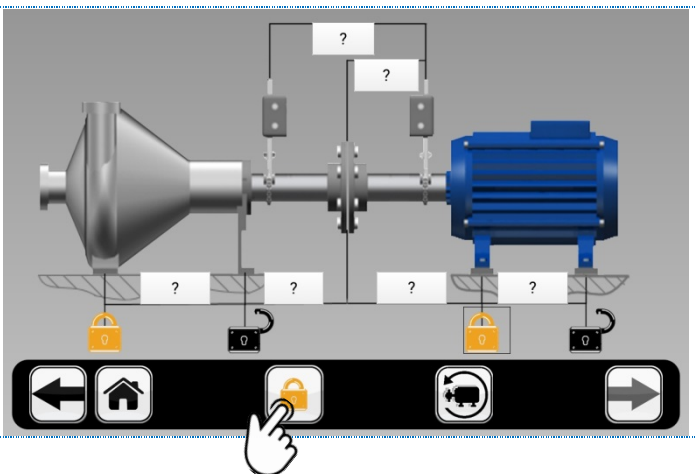

Hint:

Use a tape measure to measure:

1. The distances between the centers of the racks of the units M and S;

2. The distance between the center of the coupling and the center of the rack unit M;
3. The distance between the center of the coupling and the first pair of feet of the machine with the measuring unit M;
4. The distance between the first and second pair of feet of the machine with the measuring unit M;
5. The distance between the center of the coupling and the first pair of feet of the machine with the measuring unit S;
6. The distance between the first and second pair of feet of the machine with the measuring unit S;
7. Go to the measurement, click on the arrow icon.

18.6. Locking feet for machines with space shaft

Tap the padlock icon to indicate which pairs of feet are locked in your case.

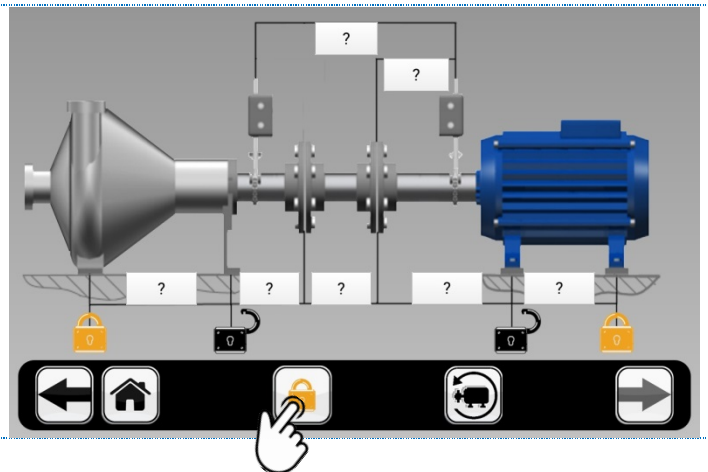

Hint:

Use a tape measure to measure:

1. The distances between the centers of the racks of the units M and S;
2. The distance between the center of the coupling and the center of the rack unit M;
3. The distance between the center of the coupling and the first pair of feet of the machine with the measuring unit M;
4. The distance between the first and second pair of feet of the machine with the measuring unit M;
5. The distance between the center of the coupling and the first pair of feet of the machine with the measuring unit S;
6. The distance between the first and second pair of feet of the machine with the measuring unit S;
7. Distance between half coupling centers;
8. Go to the measurement, click on the arrow icon.

18.7. Soft Foot Measurement Check

Completely loosen all bolts, then tap the Soft foot icon next to one of the feet in any order.

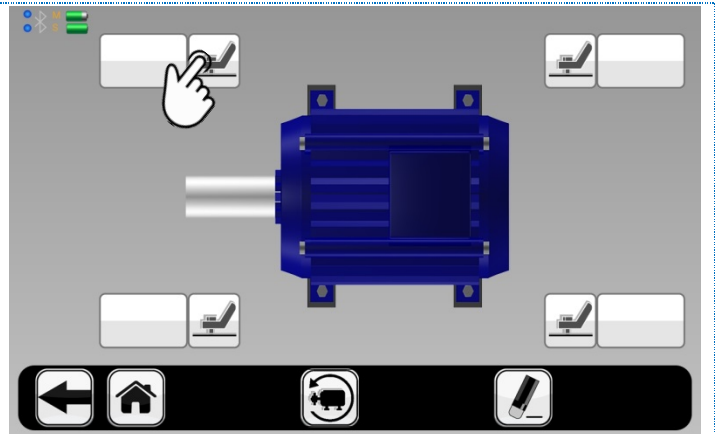

Measure the value on each foot (support).

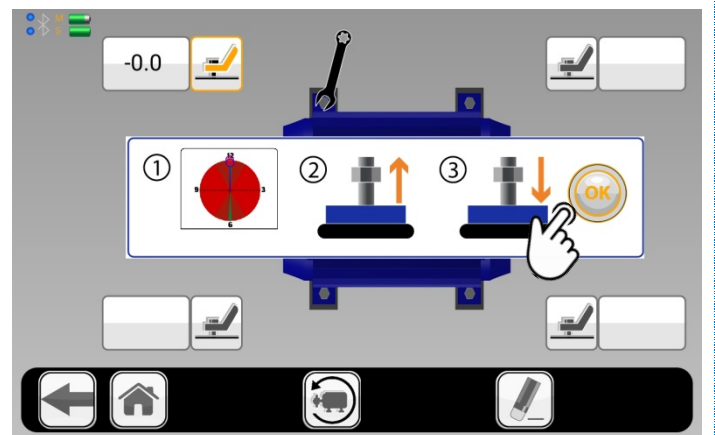

Hint:

1. Before starting the measurement, all bolts must be loosened;
2. Make sure the measuring units are at the 12 o'clock position;
3. Tighten the selected bolt;
4. Loosen the selected bolt;
5. Click ok;
6. Repeat the procedure on each of the feet;
7. To reset the measurement results, click on the icon with the image of an eraser.

18.8. Measurement results

The values show the approximate thickness of the calibrated plates to eliminate the gap between the feet (supports).

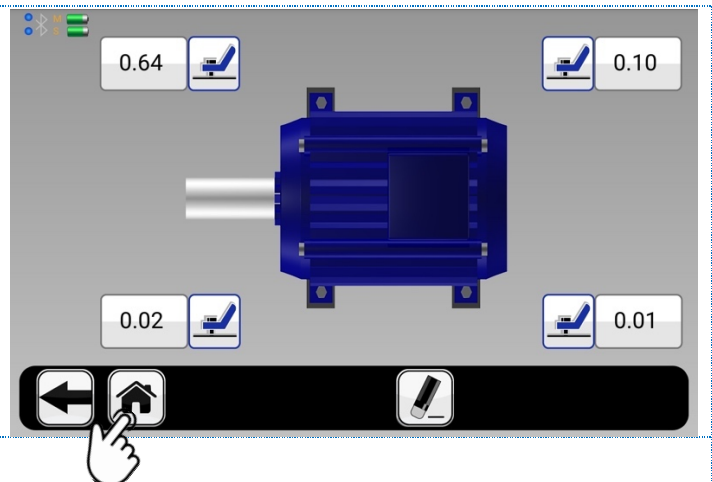

Hint:

1. To achieve accurate alignment results valid values are from 0 mm to 0.06 mm;
2. When you click on the icon with the image of the eraser, the measurement values are erased;
3. Click the home icon to continue working with other functions.

19. HORIZONTAL ALIGNMENT

Tap Horizontal alignment icon.



19.1. Selection of tolerances and coupling type

Tap the Select Tolerances icon to start a new alignment job.

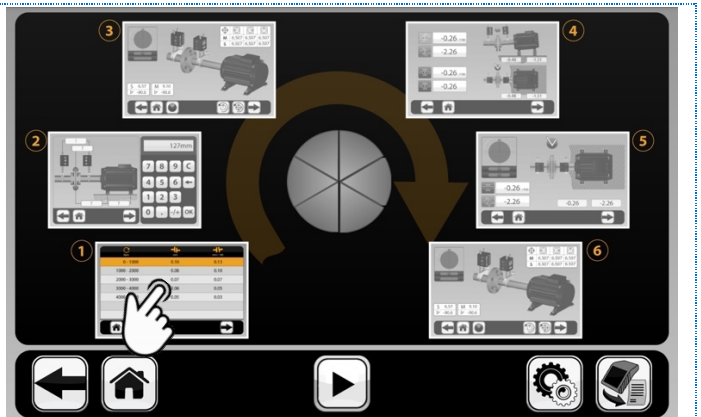

Tap the Start alignment icon (If you want to delete the results of the previous alignment and start a new one)



Select Tolerances based on the speed of the machine or tap the plus icon to enter your tolerance values.

Rpm	mm	mm / 100
0-1000	0.08	0.09
1000-2000	0.07	0.07
2000-3000	0.05	0.05
3000-4000	0.03	0.03
4000-5000	0.01	0.01
5000-6000	0.01	0.01

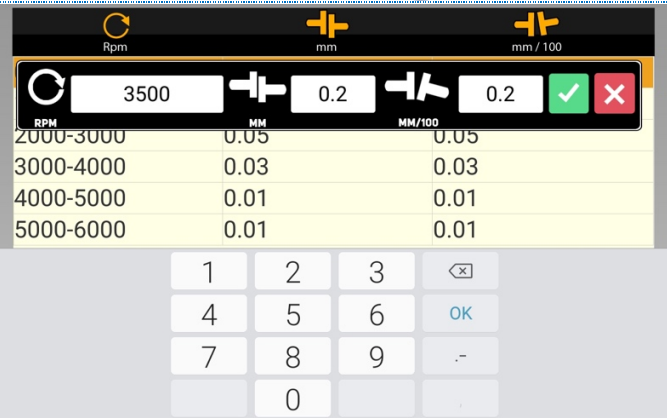

Select coupling type (machine):



Coupling



Space shaft



Cardan shaft

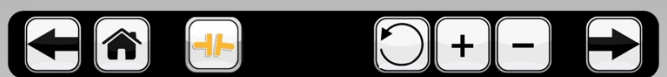

Hint:

1. Individual tolerance values are entered through a point (as shown on screen 0.2);
2. To remove unnecessary tolerance values from the table, select them and tap the minus icon;
3. To return the original tolerance values, tap the Return Values icon (to the left of the Plus icon);
4. Go to the measurement, click on the arrow icon.

19.2. Distances Measurement

Fill in the values in the windows with the question mark

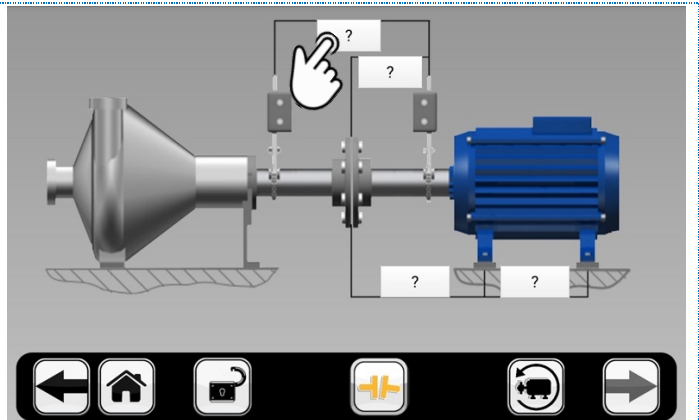

Hint:

Make sure the measuring units are at the 12 o'clock position as indicated on the screen.

Use a tape measure to measure:

1. The distances between the centers of the racks of the units M and S;
2. The distance between the center of the coupling and the center of the rack unit M;
3. The distance between the center of the coupling and the first pair of feet of the moving machine;
4. The distance between the first and second pair of feet of the moving machine;
5. Go to the measurement, click on the arrow icon.

19.3. Distances measurement for machine with space shaft

Fill in the values in the windows with the question mark

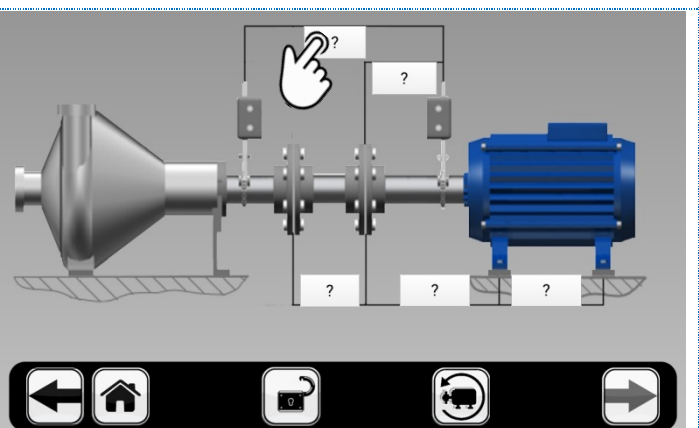

Hint:

Make sure the measuring units are at the 12 o'clock position as indicated on the screen.

Use a tape measure to measure:

1. The distances between the centers of the racks of the units M and S;

2. The distance between the center of the coupling and the center of the rack unit M;
3. The distance between the center of the coupling and the first pair of feet of the moving machine;
4. The distance between the first and second pair of feet of the moving machine;
5. Distance between the half coupling centers;
6. Go to the measurement, click on the arrow icon.

19.4. Distances measurement for a machine with a cardan shaft

Fill in the values in the windows with the question mark

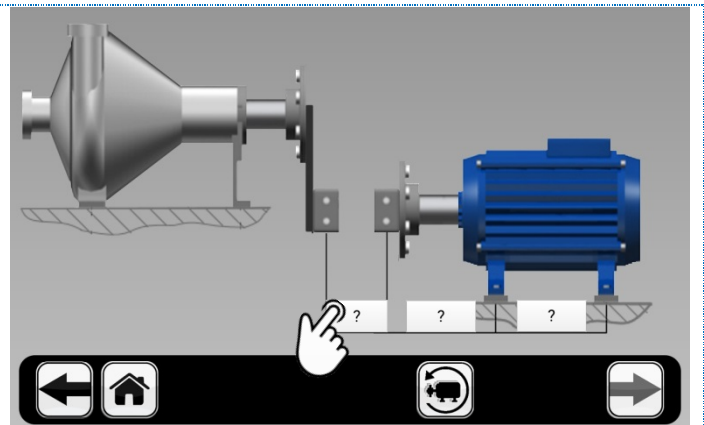

Hint:

Make sure the measuring units are at the 12 o'clock position as indicated on the screen.

Use a tape measure to measure:

1. The distances between the centers of the racks M and S;
2. The distance between the center of the rack M and the first pair of feet of the mobile machine;
3. The distance between the first and second pair of feet of the moving machine;
4. Go to the measurement, click on the arrow icon.

19.5. Locking Feet

Tap the padlock icon to indicate which pairs of feet are locked in your case.

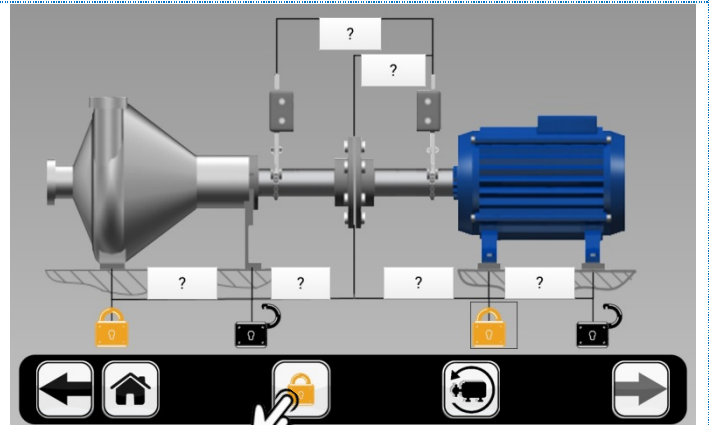

Hint:

Use a tape measure to measure:

1. The distances between the centers of the racks of the units M and S;
2. The distance between the center of the coupling and the center of the rack unit M;
3. The distance between the center of the coupling and the first pair of feet of the machine with the measuring unit M;
4. The distance between the first and second pair of feet of the machine with the measuring unit M;
5. The distance between the center of the coupling and the first pair of feet of the machine with the measuring unit S;
6. The distance between the first and second pair of feet of the machine with the measuring unit S;
7. Go to the measurement, click on the arrow icon.

19.6. Locking feet for machines with space shaft

Tap the padlock icon to indicate which pairs of feet are locked in your case.

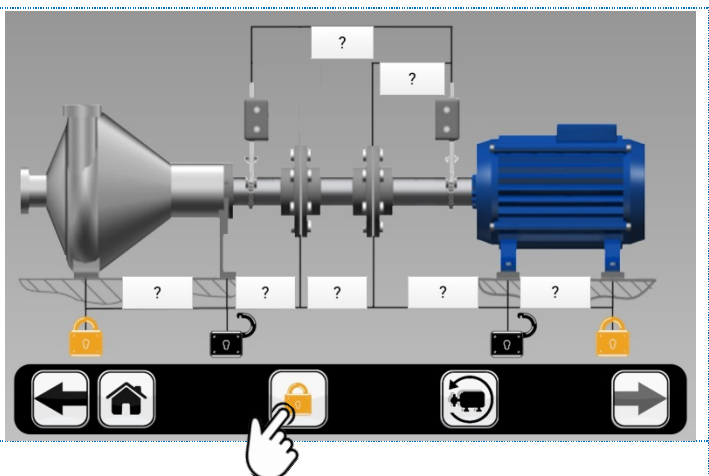

Hint:

Use a tape measure to measure:

1. The distances between the centers of the racks of the units M and S;
2. The distance between the center of the coupling and the center of the rack unit M;

3. The distance between the center of the coupling and the first pair of feet of the machine with the measuring unit M;
4. The distance between the first and second pair of feet of the machine with the measuring unit M;
5. The distance between the center of the coupling and the first pair of feet of the machine with the measuring unit S;
6. The distance between the first and second pair of feet of the machine with the measuring unit S;
7. Distance between half coupling centers;
8. Go to the measurement, click on the arrow icon.

19.7. Measurement method 9-12-3

The measurement procedure is the same for units with or without space or cardan shafts. In this case, the screens during the measurement process will be common to all types.

Choose a measurement method 9-12-3.

Set the measuring units M and S to the 9 o'clock position so that they have approximately the same angle of rotation and Tap the icon to take readings.

Set the measuring units to the 12 o'clock position and tap the Read icon.

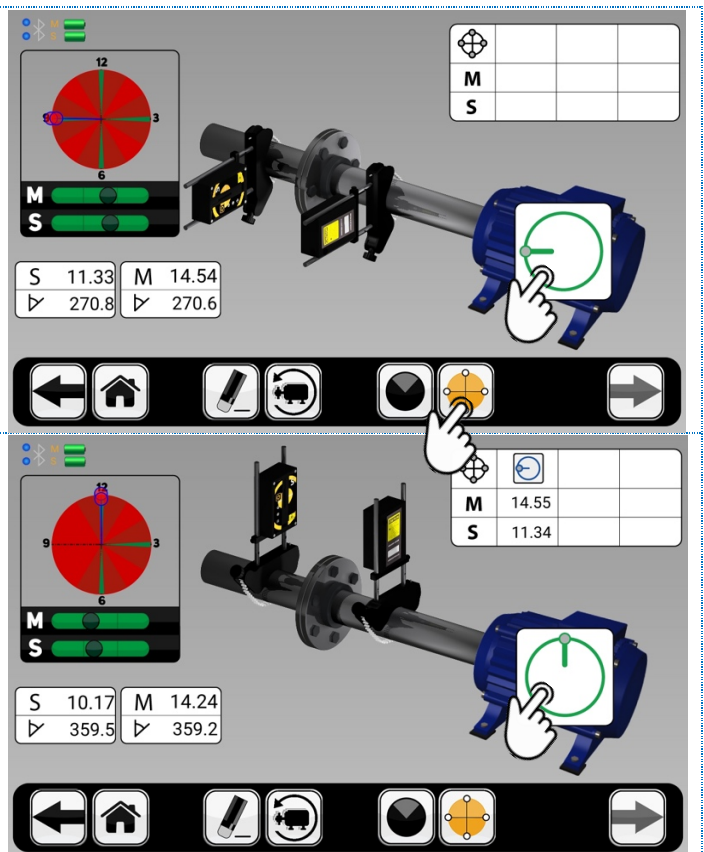

Set the measuring units to 3 o'clock and Tap the icon to read indications.

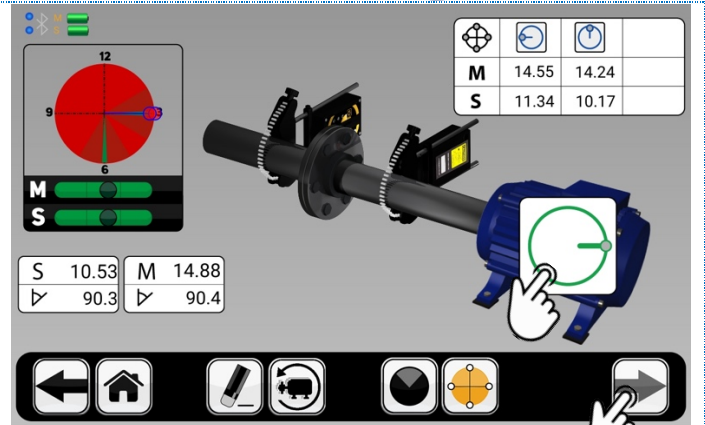

Hint:

1. Install the sensors M and S so that they have the same angle of rotation, the difference in the readings of the angle should exceed 3 degrees (the size of the green zone of the bubble level). The position of the bubbles of the virtual level exactly in the center of the measuring zone displays the exact positioning of the sensors in 9-12-3 hours;
2. Observe the sequence 9-12-3 when rotating the measuring units for reading;
3. Before taking measurements, control backlash;
4. Do not rotate the shafts with fixings of measuring units, measuring units or a chain;
5. Do not change the position of the measuring units after the measurement;
6. In the table in the upper right part of the screen, the position values of the laser beam on the detector are entered;
7. Go to the measurement, click on the arrow icon.

19.8. Inclinometer off measurement

If it is not possible to take measurements with an inclinometer (at extremely high vibration), use the "Measure without inclinometer" function. In this case, the user must independently set the measuring unit to the position specified by the program.

Choose a measurement method 9-12-3.

Tap the Inclinometer Off icon

Set the measuring units M and S to the 9 o'clock position so that they have approximately the same angle of rotation and tap the Take a readings icon to record.

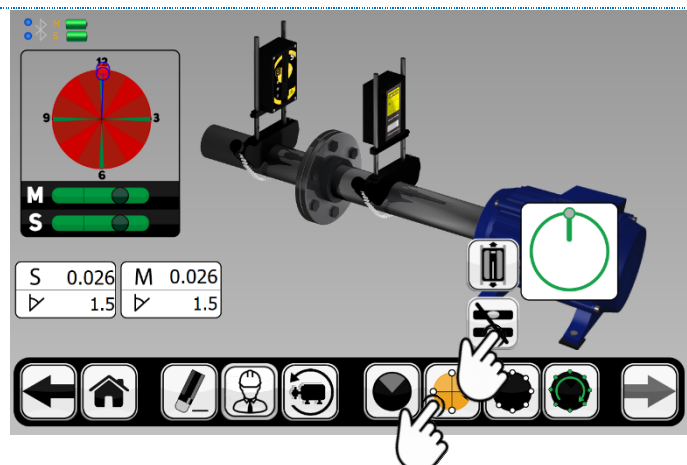

After the measuring units have moved to the next position on the screen - set the measuring units to the 12 o'clock position and tap the Take a Readings icon to record.

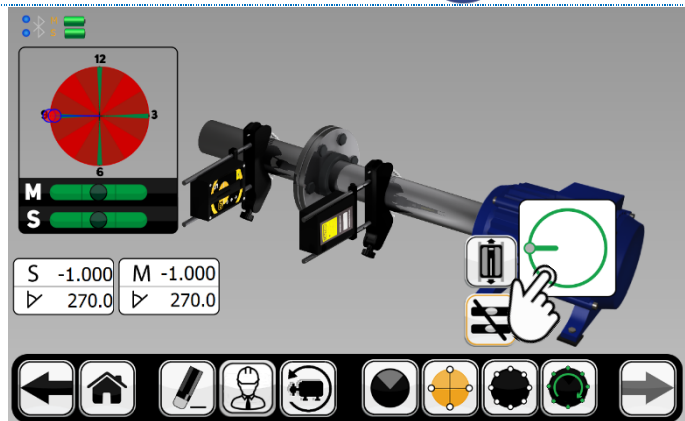

After the measuring units have moved to the next position on the screen - set the measuring units to the 3 o'clock position and tap the Take a Readings icon to record.

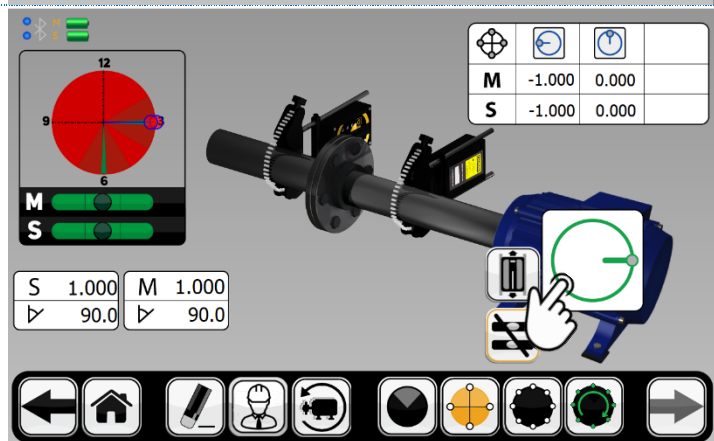
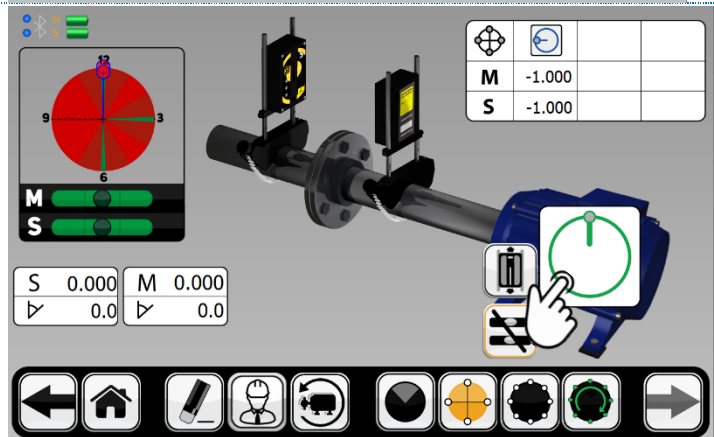

Hint:

1. Observe the sequence 9-12-3 when rotating the measuring units for reading;
2. Before taking measurements, control backlash;
3. Do not rotate the shafts with fixings of measuring units, measuring units or a chain;
4. Do not change the position of the measuring units after the measurement;
5. In the table in the upper right part of the screen, the position values of the laser beam on the detector are entered;
6. Go to the measurement, click on the Arrow icon.

19.9. Multi-point method SmartPoints™

The measurement procedure is the same for units with or without space or cardan shafts. In this case, the screens during the measurement process will be common to all types of aggregates.

Select a multi-point method.

Select any position of the measuring units tap the Start icon to take measurement

Take measurements by sequential (step by step) movement of the sensors from one position to the next.

The measurement result is recorded automatically.

After the Hourglass icon disappears, you can tap the Take readings icon to the left of the Stop icon to manually fix the result at the selected point.

The Stop icon displays the number of points (measurements).

Tap the Stop icon to finish measuring.

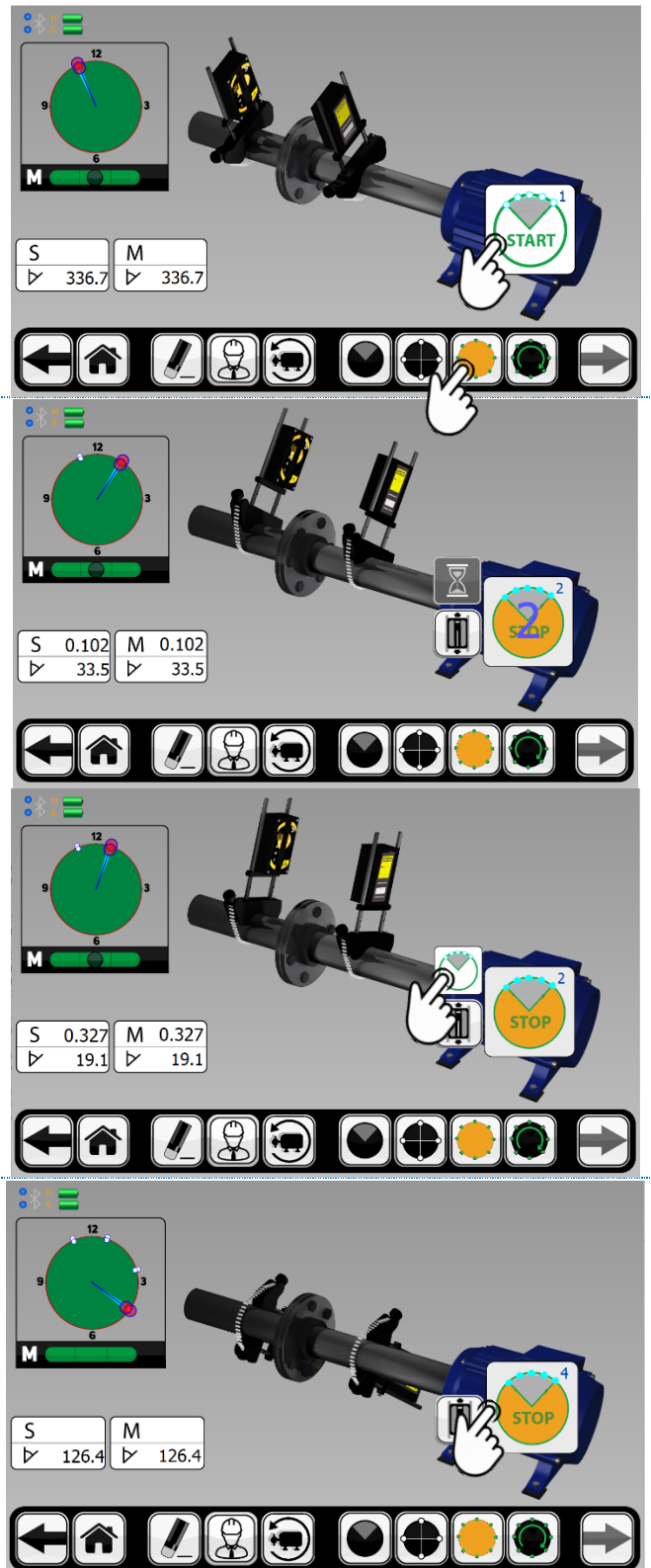

Hint:

1. It is recommended to use this method: when aligning the shafts installed in the plain bearings; when aligning large aggregates;
2. We recommend that you meet the following conditions: 360 ° rotation angle; number of measurements 100 points;
3. The minimum value of the angle of rotation of the shaft required for measurements is 3 degrees;
4. Do not rotate the shafts with fixings of measuring units, measuring units or a chain;
5. Before taking measurements, control backlash;
6. Take the measurement by turning the sensors in one direction;
7. Watch the values of the angle of rotation, the difference in the indications of the angle of the measuring units should not exceed 3 degree (the size of the green zone of the bubble level);
8. Go to the measurement results by clicking on the arrow icon.

19.10. Uninterrupted method SmartSpin™

The measurement procedure is the same for units with or without space or cardan shafts. In this case, the screens during the measurement process will be common to all types of aggregates.

Select an uninterrupted method.

Select any position of the measuring units to start the measurement. Click the start measurement icon.

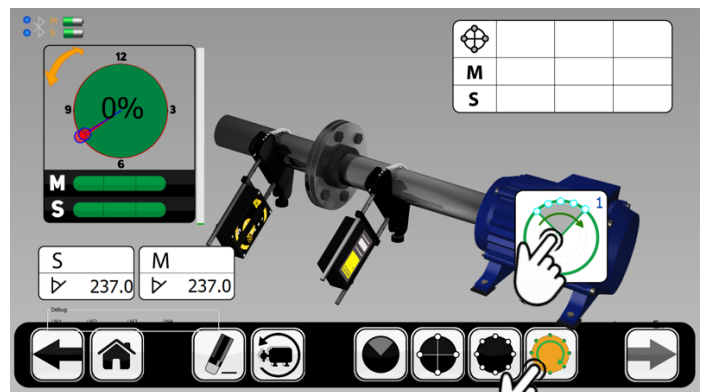

Take a measurement by turning the sensors evenly in one direction at the same speed. Click complete measurement icon.

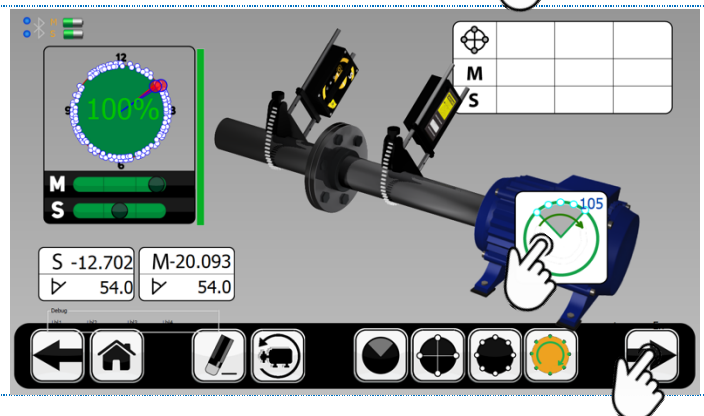

Hint:

1. It is recommended to use this method when aligning the shafts installed in the plain bearings; when aligning large aggregates;
2. To obtain the best measurement result - the value on the indicator should be 100%;
3. Do not rotate the shafts with fixings of measuring units, measuring units or a chain;
4. Before taking measurements, control backlash;
5. Take the measurement by turning the sensors in one direction;
6. Watch the values of the angle of rotation, the difference in the indications of the angle of the measuring units should not exceed 3 degree (the size of the green zone of the bubble level);
7. Go to the measurement results by clicking on the arrow icon.

19.11. The cut angle method SmartAngle™

The measurement procedure is the same for units with or without space or cardan shafts. In this case, the screens during the measurement process will be common to all types of aggregates

Select Cut angle method.

Set the measuring units M and S so that they have the same angle of rotation and tap the icon Take readings.

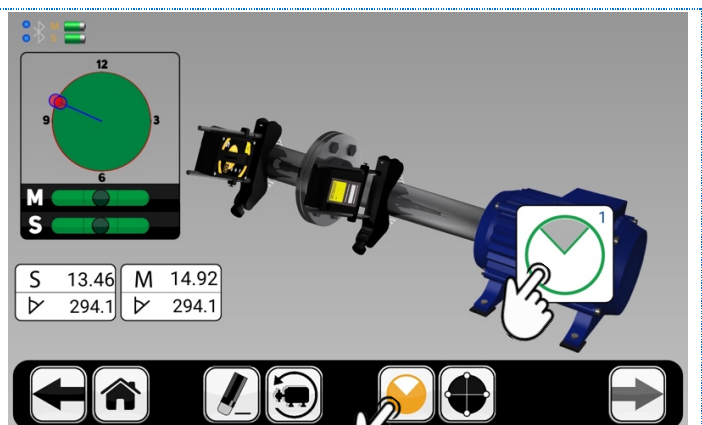

Set the measuring units to the next position and tap the Take readings icon.

For the following measurements, it is necessary to remove the sensors from the red zone.

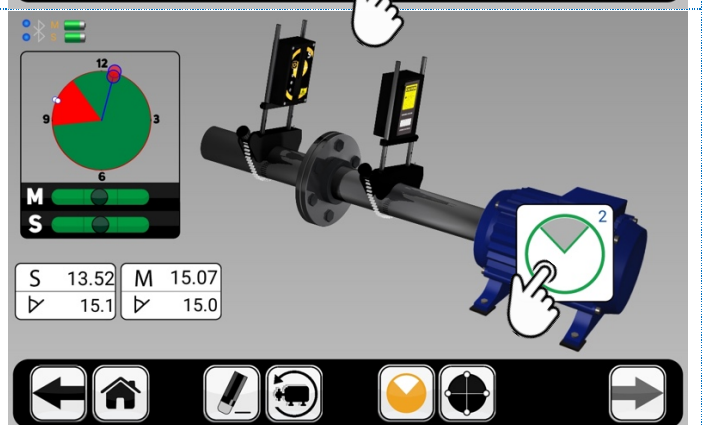

Set the measuring units to the last position and tap the Take readings icon.

For the following measurements, it is necessary to remove the sensors from the red zone.

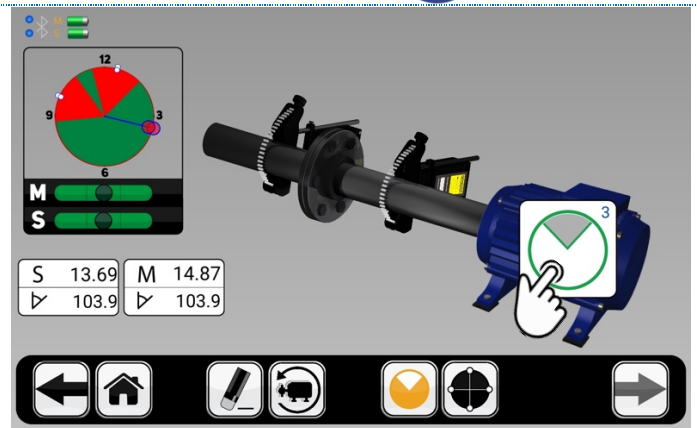

Hint:

1. It is recommended to use this method in the absence of the measurement method 9-12-3;
2. The minimum value of the angle of rotation of the shaft required for measurements is 40 degrees;
3. Before taking measurements, control backlash;
4. Take a measurement by turning the sensors in one direction;
5. Do not rotate the shafts with fixings of measuring units, measuring units or a chain;
6. Watch the values of the angle of rotation, the difference in the indications of the angle of the measuring units should not exceed 3 degree (the size of the green zone of the bubble level);
7. Go to the measurement, click on the arrow icon.

19.12. SmartShift™

When it's necessary to change the position of the laser units or change the position of the laser on the detector during the measurement, you have to use feature the SmartShift™

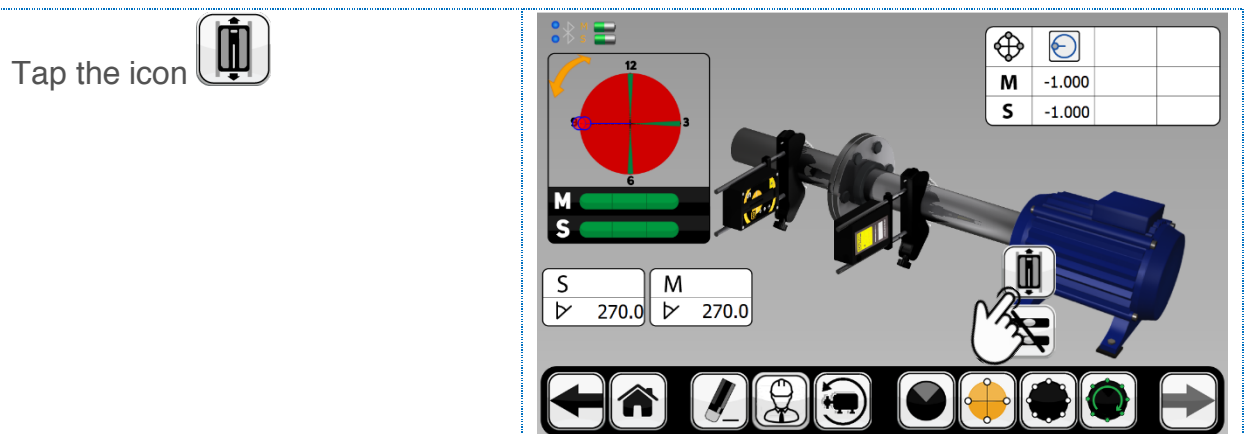

Change the position of the laser units relative to the rods (by lifting them up or down) or change the direction of the laser using the adjusting screw.

Then Tap icon  again.

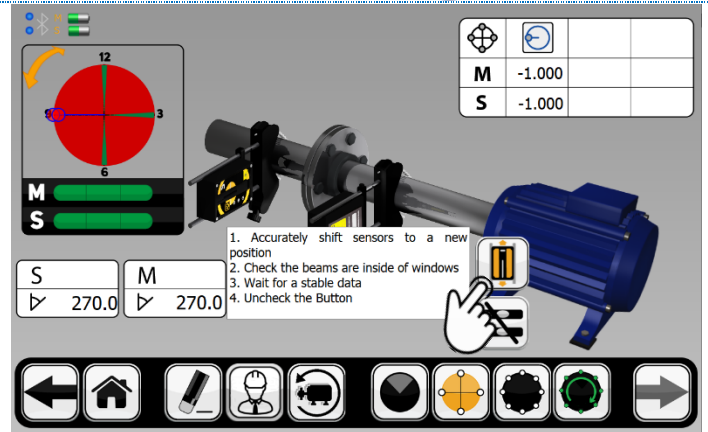







Hints:

1. After changing the position, wait until the data in the S and M windows will become stable;
2. Move the measuring units smoothly and slowly;
3. Make sure that the laser beam is not outside the detector before Tap the icon ;
4. Do not move the mounts of the laser units horizontally.

19.13. Measurement results

The screen displays the alignment values for the coupling and the position of the supports, both in the vertical and horizontal directions. The symbol to the left of the misalignment values indicates the direction of kink and offset, and also indicates whether the values are within tolerance.

Within the tolerance (the symbol is colored green)	
Within double tolerance (symbol is colored yellow)	
Outside of double tolerance (symbol is colored red)	
The symbol next to the coupling duplicates the tolerance reading:	
Within tolerance	
Within double tolerance	
Outside Double Tolerance	

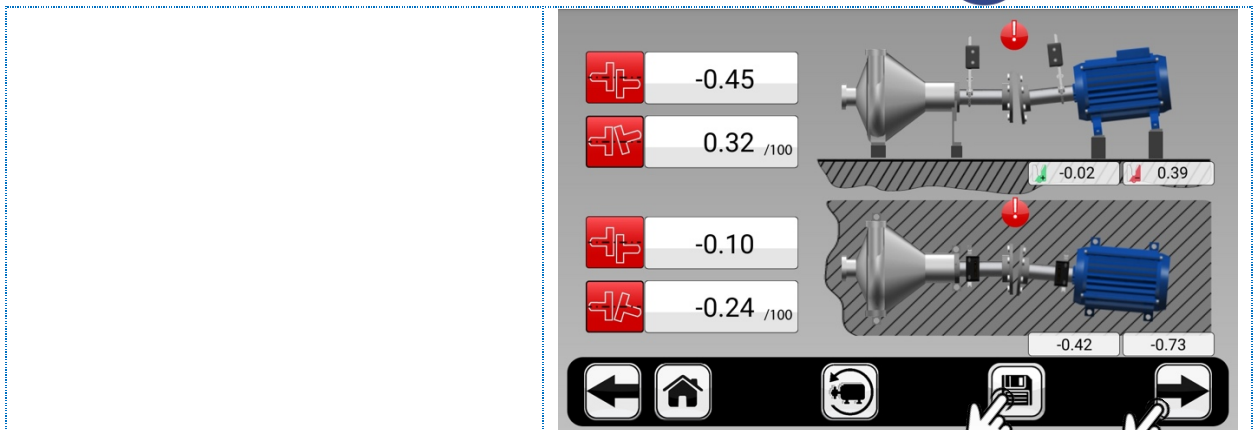

Hint:

1. Save the results by tapping the diskette icon;
2. The upper part of the screen displays the vertical results, and bottom part - horizontal;
3. The left part of the screen in the first and third lines indicate the values of the shaft shifts (-0.45 and -0.10), in the second and fourth lines - breaks (0.32 / 100 and -0.24 / 100);
4. On the right side of the screen is the approximate size of the plates to be placed (image of the plates in green) or removed (the image of the plates in red);
5. Go to life alignment mode in the vertical position by clicking on the arrow icon.
6. If it is necessary to carry out measurements again, click on the icon with the left arrow, and then in the measurement window click on the eraser icon. Then carry out measurements with the chosen method.

19.14. Results screen for space shaft machines



Hint:

1. Save the results by tapping the diskette icon;
2. The upper part of the screen displays the vertical results, and bottom part - horizontal;

3. In the left part of the screen in the first and third lines are indicated the breaks between the stationary machine and the space shaft, and in the second and fourth lines - between the space shaft and the movable machine;
4. On the right side of the screen is the approximate size of the plates to be placed (image of the plates in green) or removed (the image of the plates in red);
5. Go to life alignment mode in the vertical position by clicking on the arrow icon.
6. If it is necessary to carry out measurements again, click on the icon with the left arrow, and then in the measurement window click on the eraser icon. Then carry out measurements with the chosen method.

19.15. Results screen for machines with cardan shaft

Results screen for machines with Cardan Shaft.

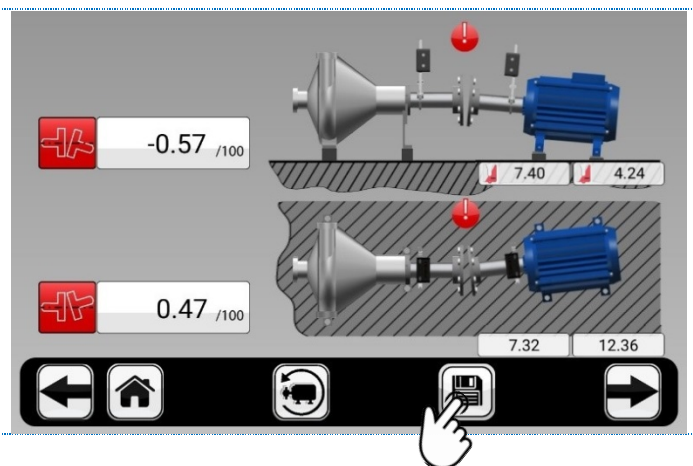

Hint:

1. Save the results by tapping the diskette icon;
2. The upper part of the screen displays the vertical results, and bottom part - horizontal;
3. The left side of the screen shows the values of the break of the shaft line;
4. On the right side of the screen is the approximate size of the plates to be placed (image of the plates in green) or removed (the image of the plates in red);
5. Go to life alignment mode in the vertical position by clicking on the arrow icon.
6. If it is necessary to carry out measurements again, click on the icon with the left arrow, and then in the measurement window click on the eraser icon. Then carry out measurements with the chosen method.

19.16. Shims Calculator

Allows user simulate changes in alignment results with virtual movement of the machine in horizontal and vertical planes.

Click the calculator icon.

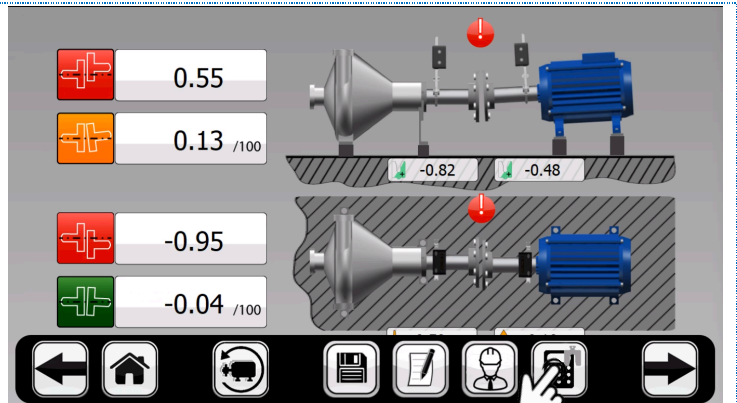

Enter the total thickness of the shims that you want to place under the pair of feet (support) in the value field and click OK.

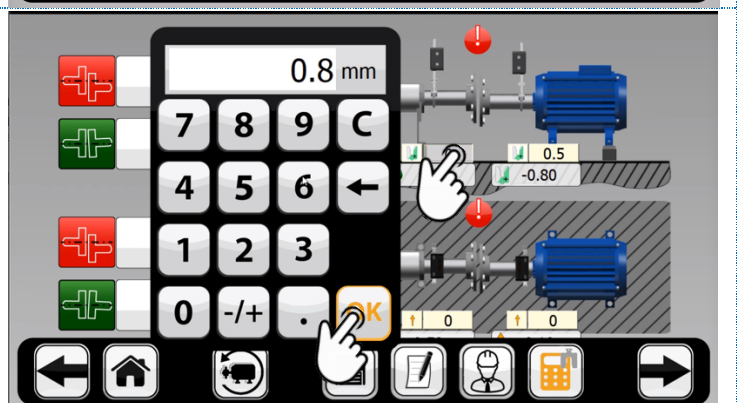
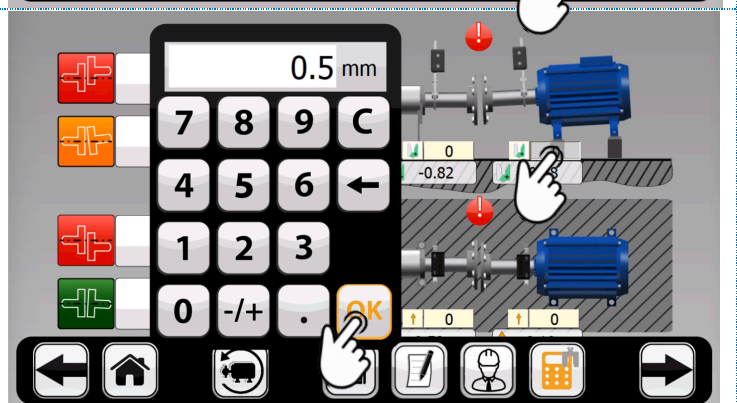

The calculated vertical alignment value will be displayed on the screen.

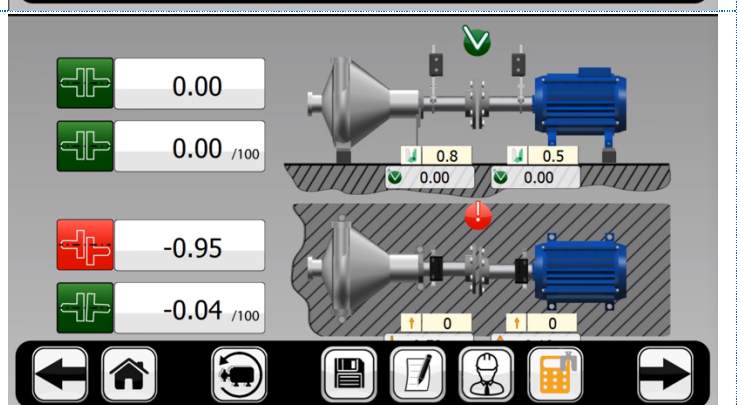

Hint:

1. Follow the same steps to calculate the horizontal alignment value by entering your offsets.

19.17. Repeatability table

Select the repeatability table icon on the result screen.

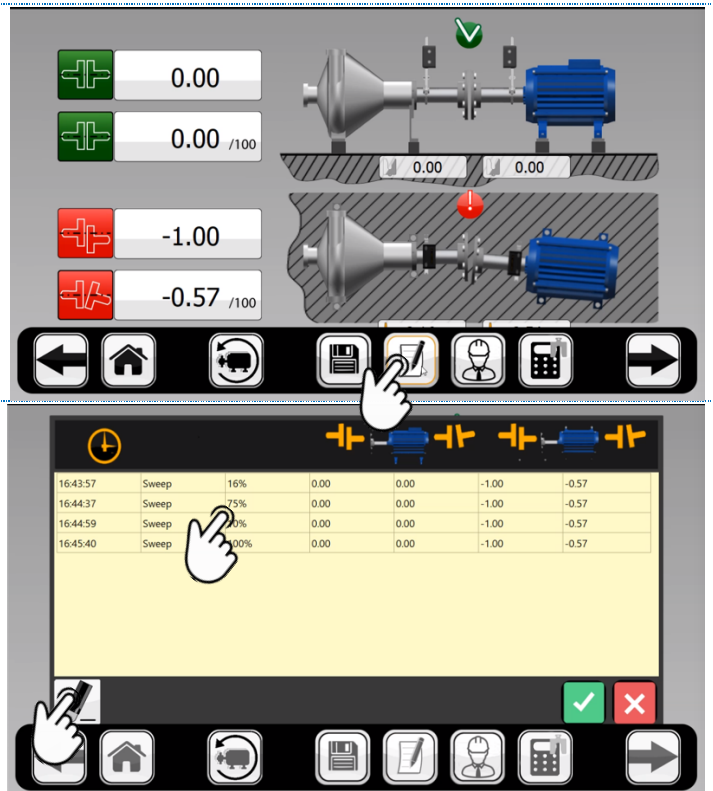

The screen will display the last 10 measurements that you have taken.

Hint:

1. Click the eraser icon in order to clear the table.

19.18. Indicator conversion calculator

If the results need to be presented in the indicators readings tap the Transfer to indicators icon.

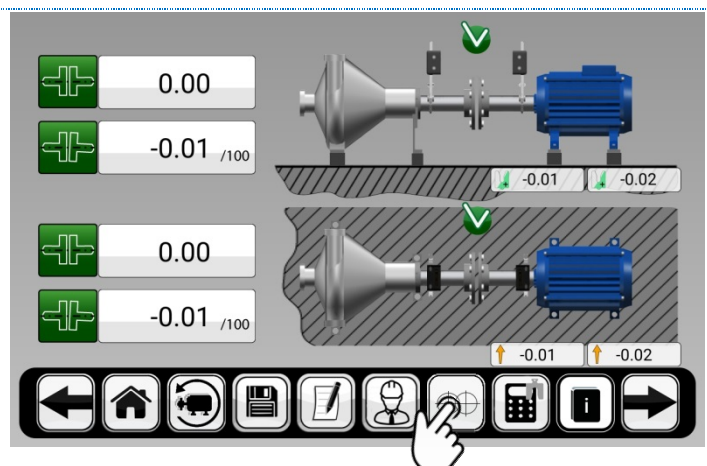

Select one of the indicator scenarios and specify the required distances.

 reverse dial indicator method

 radial-axial method

 3 indicators radial-axial method

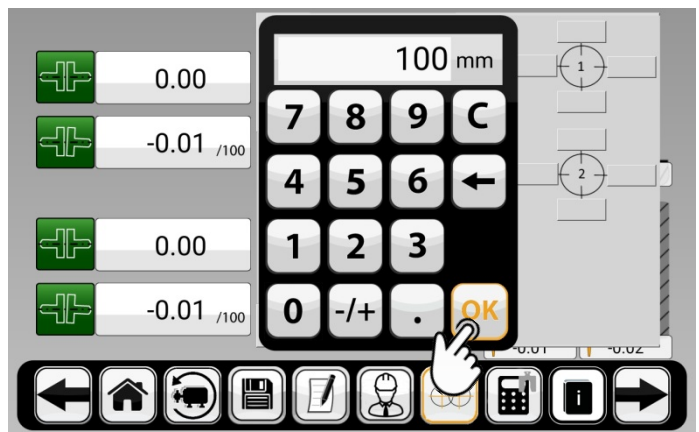
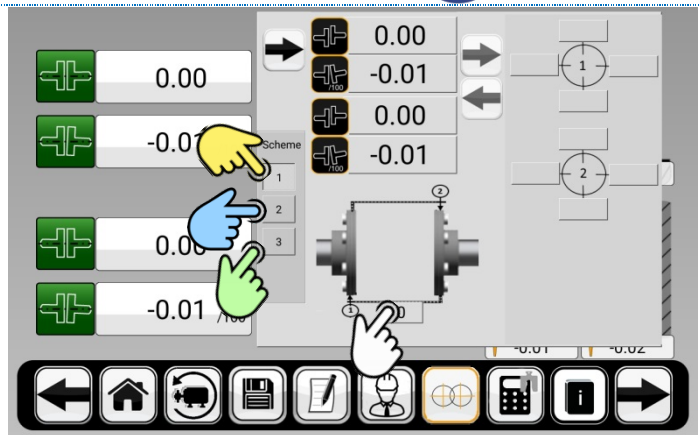

Tap the Right arrow icon to convert values to the indicator's readings.

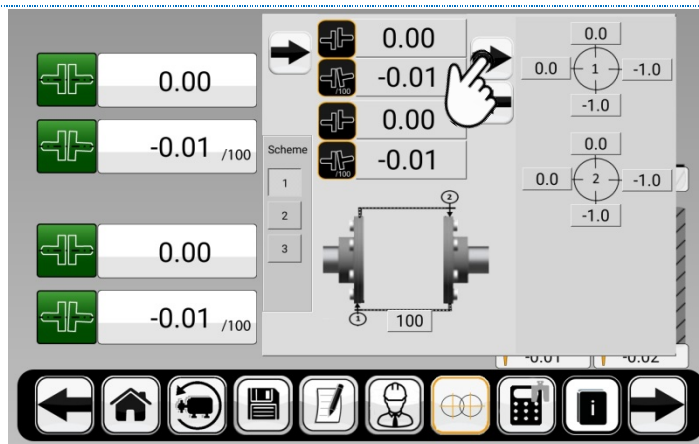

Hint:

1. The data is intended for comparison or analysis of results and will not be displayed in the report;
2. You can enter your data in the indicator fields to calculate what values should be obtained. To do this, fill in the fields around the indicators and tap the Left arrow icon.

19.19. Live alignment in the vertical direction

Adjust the position of the machine in the vertical direction.

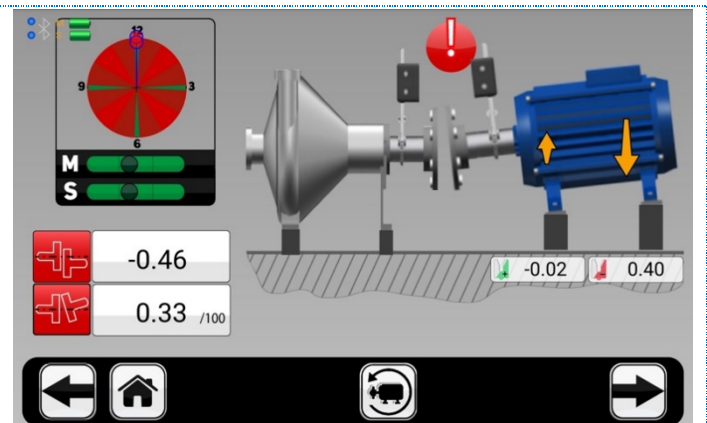

Hint:

1. To adjust in the vertical direction, set the measuring units from the 3 o'clock position to the 12 o'clock position;
2. After adjusting the machine in the vertical direction, tighten the bolts and check whether the values remain within the tolerance, since various structural defects (foundation, frame) can create an error in the result;
3. Go to life alignment mode in the horizontal position by rotating units **3 o'clock** position

19.20. Live alignment in vertical direction for machines with space shaft

Adjust the position of the machine in the vertical direction.

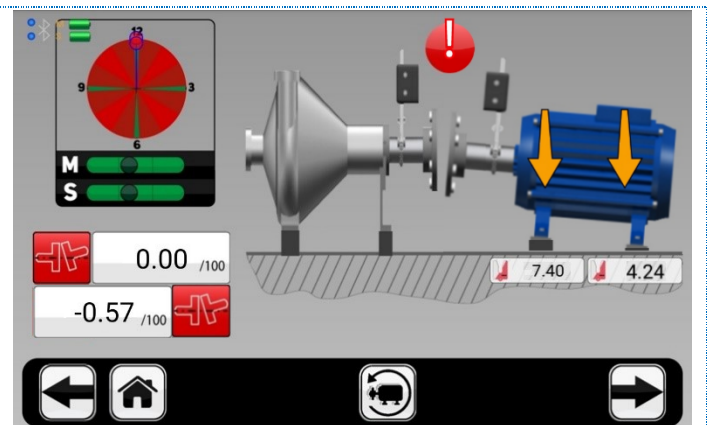

Hint:

1. To adjust in the vertical direction, set the measuring units from the 3 o'clock position to the 12 o'clock position;
2. After adjusting the machine in the vertical plane, tighten the bolts and check whether the values remain within the tolerance, since various structural defects (foundation, frame) can create an error in the result;
3. Go to life alignment mode in the horizontal position by rotating units **3 o'clock** position.

19.21. Live alignment in the vertical direction for machines with cardan shaft

Adjust the position of the machine in the vertical direction.

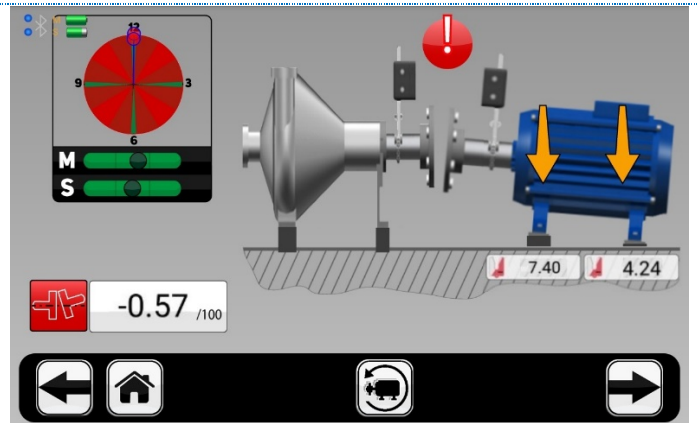

Hint:

1. To adjust in the vertical direction, set the measuring units from the 3 o'clock position to the 12 o'clock position;
2. After adjusting the machine in the vertical plane, tighten the bolts and check whether the values remain within the tolerance, since various structural defects (foundation, frame) can create an error in the result;
3. Go to life alignment mode in the horizontal position by rotating units **3 o'clock** position.

19.22. Live alignment in the horizontal direction

Live alignment in the horizontal direction is common for all types of machines.

Adjust the position of the machine in the horizontal direction.

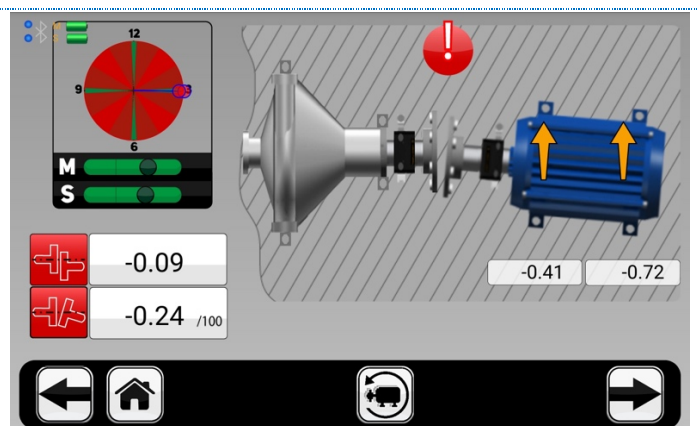

Hint:

1. To adjust in the horizontal direction, set the measuring units to the 3 o'clock position;
2. Loosen the bolts tightened after aligning the unit in a vertical position;
3. After adjusting the machine in the horizontal position, tighten the bolts crosswise to avoid the machine moving, and check whether the values remain within the tolerance;
4. Go to the control measurement mode by rotating units **3 o'clock** position.

19.23. Live alignment without using an Inclinometer

This function allows live alignment in cases of high vibration, and you will not see the rotation angle of the measuring units. The program displays position the measuring units must be moved in order to take measurements.

Tap the Inclinometer off icon

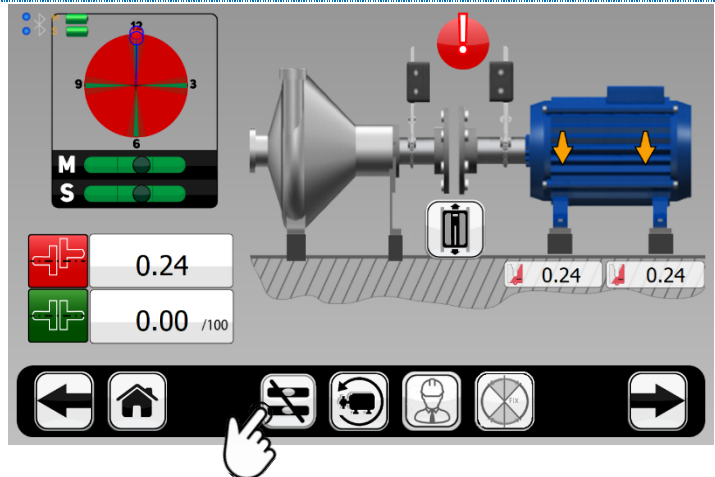

Select one of the 9, 12 and 3 position by taping the Next Position icon, then set the measuring units to the position shown on the screen.

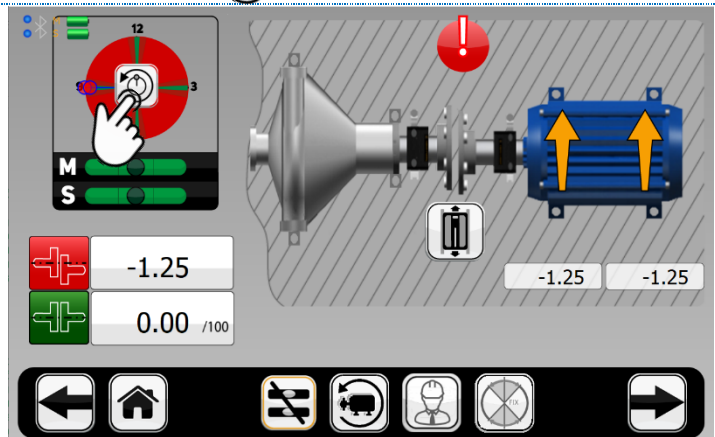

After adjusting the machine, tap the Next Position icon and set the measuring units to the indicated position.

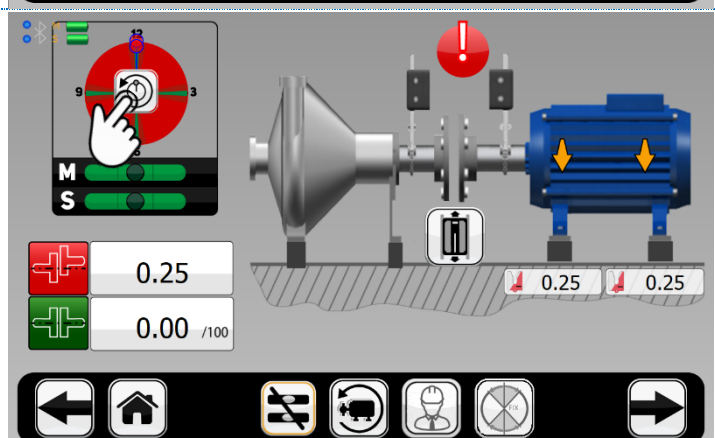

Hint:

1. After adjusting the machine in the vertical direction, tighten the bolts and check whether the values remain within the tolerance, since various structural defects (foundation, frame) can create an error in the result...especially in this mode of operation.

2. For horizontal alignment set the measuring units to the 9 or 3 o'clock position;
3. Loosen the bolts tightened after aligning the machine in a vertical position;
4. After adjusting the machine in the horizontal position, tighten the bolts crosswise at the manufacturer specified torque values to avoid the machine moving, and check whether the values remain within the tolerance
5. Go to the control measurement mode by taping the Arrow icon.

19.24. Live move mode

Allows live aligning in any angle position of the measuring units. When it is not possible to install the measuring units strictly in the 9–12–3 hours position.

This feature works by default when using the multipoint SMARTPOINTS™ and continuous SMARTSPIN™ methods.

For vertical alignment, install the measurement units in any position of the sector for 12 hours.

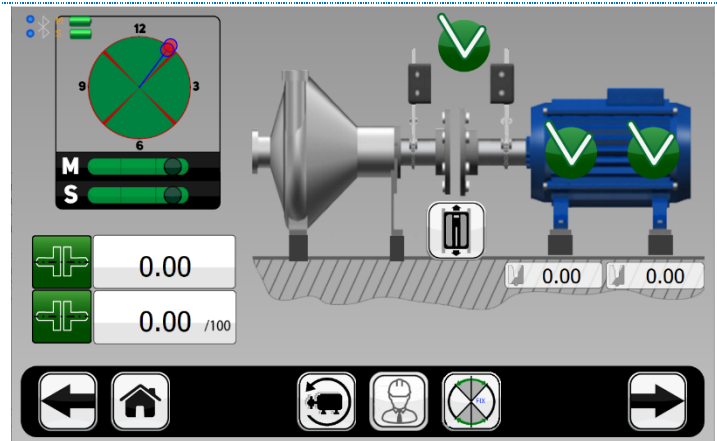

After adjusting the machine in a vertical plane click the live move mode icon.

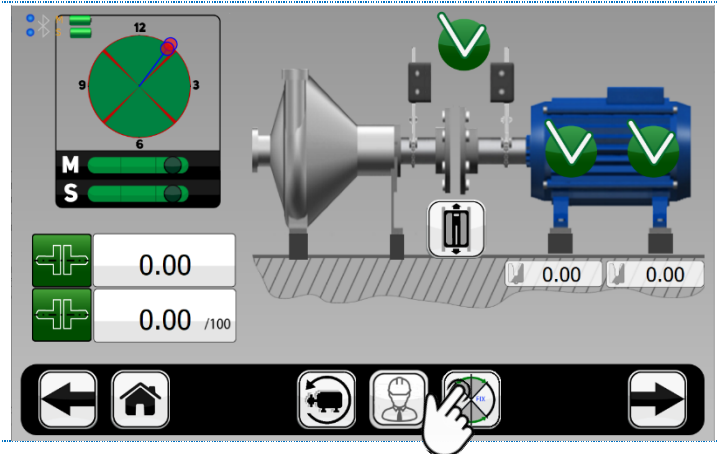

Hint:

1. After adjusting the machine in the vertical plane, tighten the bolts and check whether the values remain within the tolerance, since various structural defects (foundation, frame) can create an error in the result;
2. Go to life alignment mode in the horizontal position by rotating units **3 o'clock** position.

For horizontal alignment, install the measurement units in any position of the sectors for 9 or 3 hours.

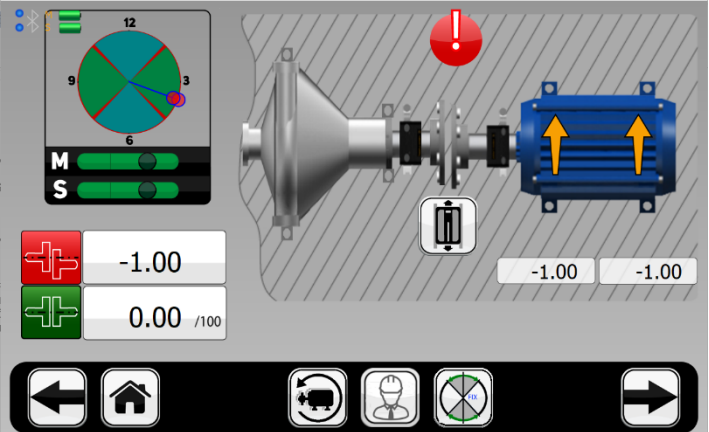

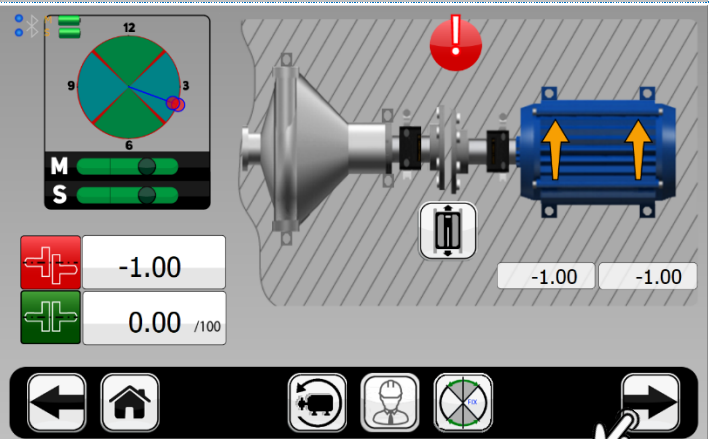

After horizontal alignment tap the  icon if you want to continue vertical adjustment.



Hint:

1. Loosen the bolts tightened after aligning the unit in a vertical position;
2. After adjusting the machine in the horizontal position, tighten the bolts crosswise to avoid the machine moving, and check whether the values remain within the tolerance;
3. Go to the control measurement mode by clicking on the arrow icon.

19.25. Alignment results

Within the tolerance (the symbol is colored green) 
 colored green)
 Within double tolerance (symbol is colored yellow) 
 colored yellow)
 Outside of double tolerance (symbol is colored red) 

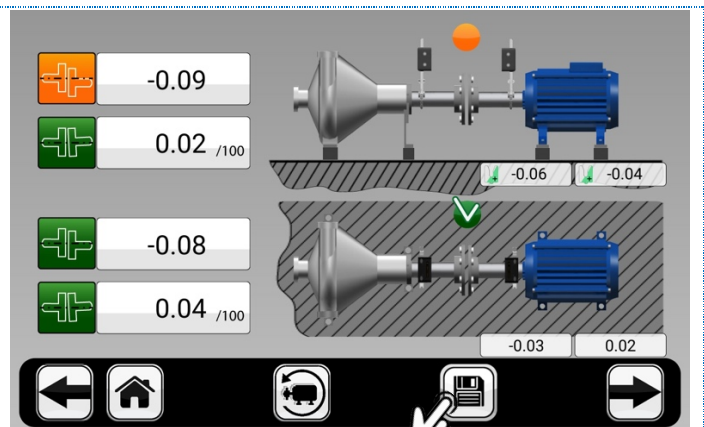

To return to the life alignment mode, click the Home icon and click on the icon of the 5th alignment step.

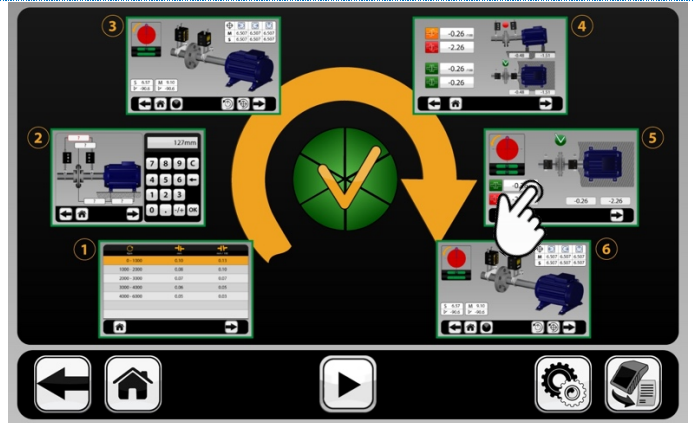

Hint:

1. Take control measurements and complete the alignment process;
2. When making control measurements, repeat the process according to the method you used before;
3. To complete the alignment process, proceed to saving reports by clicking on the icon with a diskette image.

19.26. Saving reports

In the field that appears, enter the name of the report, then click Enter and confirm the report is saved by clicking on the green checkmark or refuse to save the report.

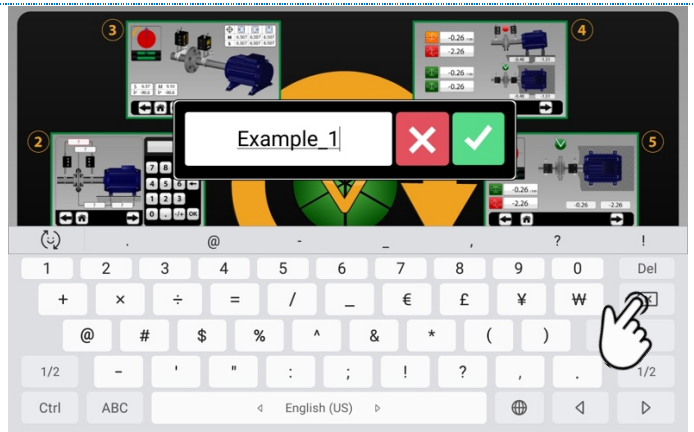

20. REPORTS

20.1. Save report as PDF file

Tap the Measurement reports icon to go to the list of all saved measurements.

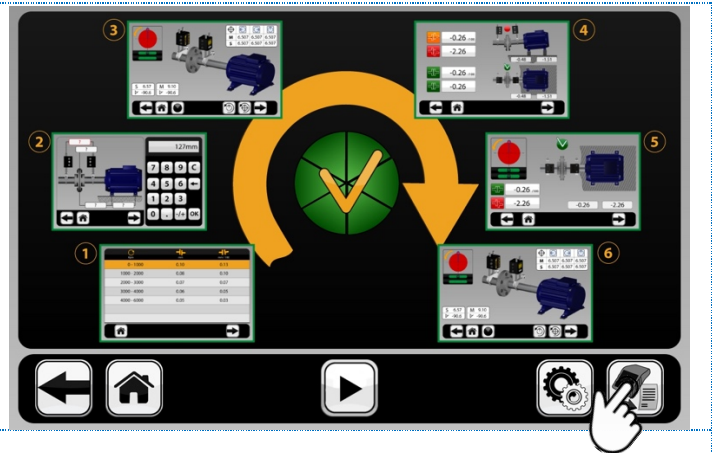

Select one of the previously saved reports and tap the Save as PDF icon to save the report to the device.

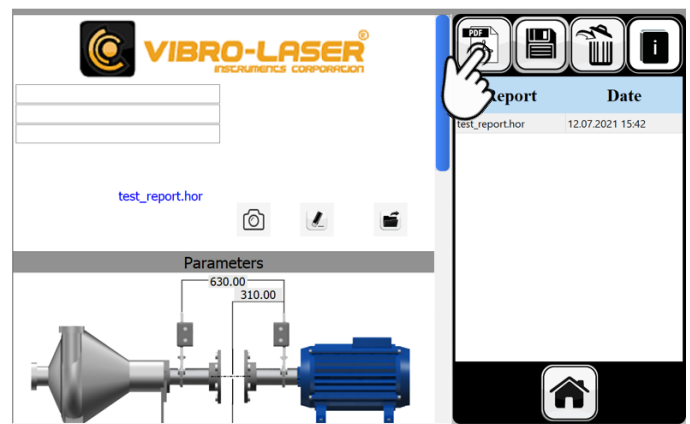

Hint:

1. All reports saved in PDF format can be found in the Documents folder on your Android, iOS device;
2. If you do not save the report in PDF format, after deleting the VIBRO-LASER Alignment app, you will no longer be able to access the reports.

20.2. Adding a logo and photo to the report

Take a photo on the tablet and save it in the gallery.

Select a photo or logo in the gallery and click Save to Files.

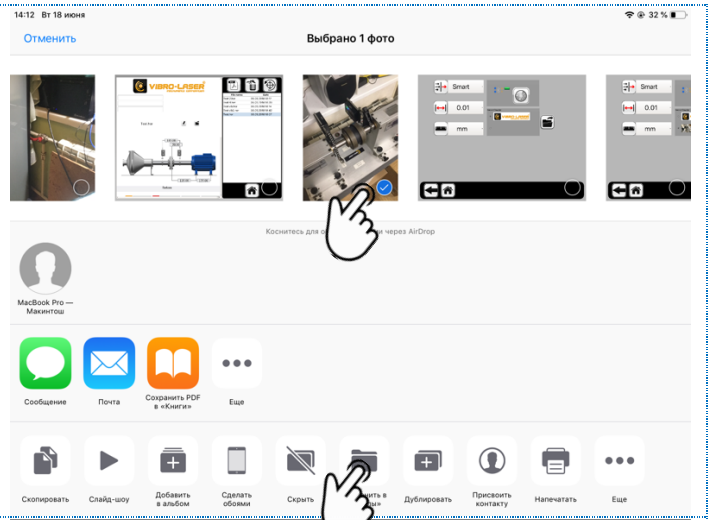

Save the photo or logo to the VIBRO-LASER Alignment folder.

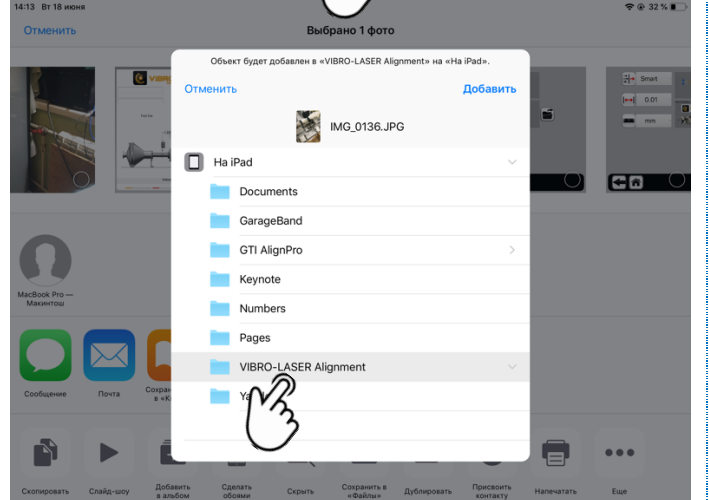

Go to the reports in the VIBRO-LASER app, click the Folder icon, select the desired photo.



Available only on iOS tablet.

To place the user's logo in the report, go to the menu screen Configure system settings and put a checkmark in front of the user's logo.



The report displays the user's logo.

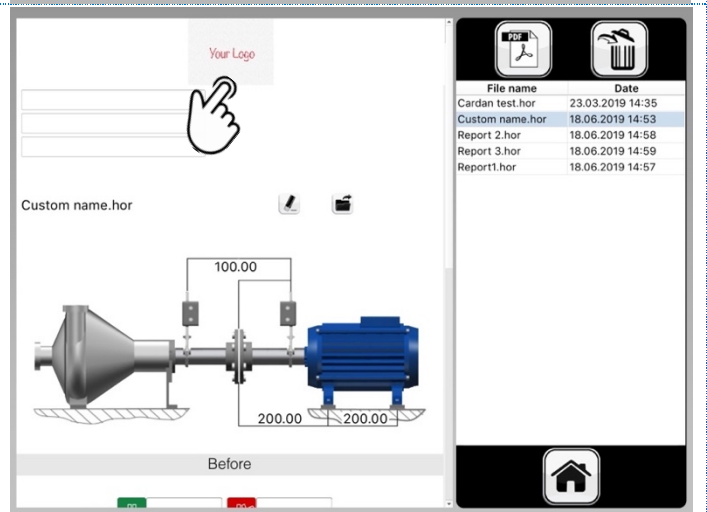

21. THERMAL GROWTH EXPANSION

21.1. Thermal expansion corrections

An icon  appears at the Measurement results stage indicating that a temperature correction has been entered.

When starting the alignment, it must be carried out on a "cold" machine.

Tap the Settings icon



In the upper field, specify the angular and axial misalignment for vertical thermal expansion, and in the lower fields for horizontal thermal expansion. This can be found in your machine's OEM manual.

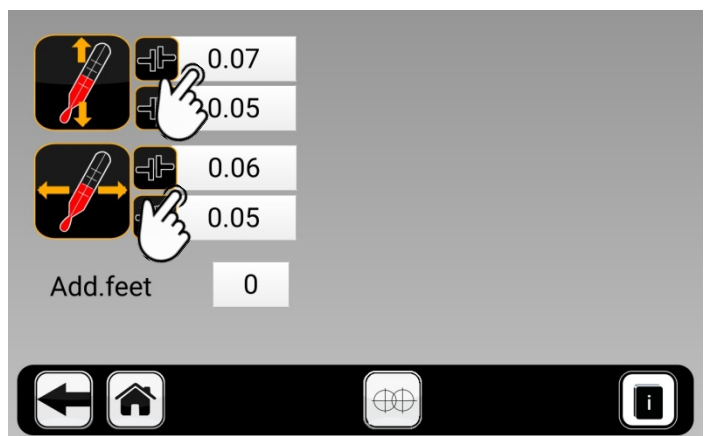

Hints:

1. If you know the thermal expansion correction for the M machine and for the S machine, enter in the fields the values equal to $M - S$. For example, on a machine with M head, the offset is 0.4 and the angle is equal to 0.3; on a machine with an S Head, the offset is 0.2, and the angle is 0.2. We find the values by the formula $M - S$ ($0.4 - 0.2 = 0.2$ and $0.3 - 0.2 = 0.1$) and write the results in the corresponding fields; the offset is 0.2, the angle is 0.1;
2. If you know the correction for thermal expansion only for the machine on which the M head is installed, enter these values into the fields as they are indicated. In this case, for the formula $M - S$, S is zero;
3. If you know the correction for thermal expansion only for the machine on which the S unit is installed, enter these values in the fields with **the opposite sign**. In this case, for the formula $M - S$, M is zero.

If the thermal expansion is presented as indicators data, tap the Conversion to indicators icon.

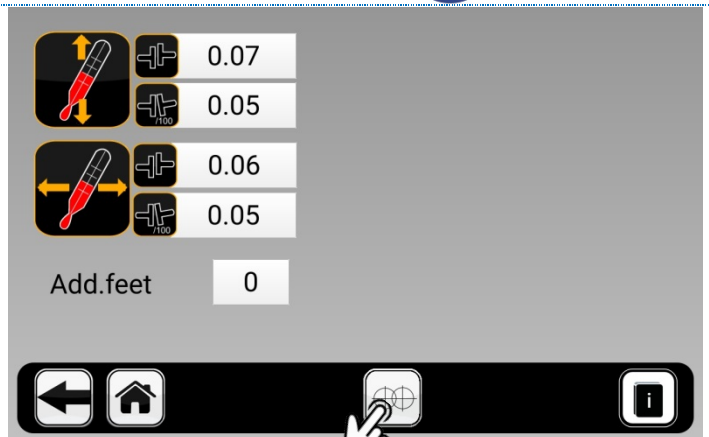

Select one of the indicator scenarios and specify the required distances.

 reverse dial indicator method

 radial-axial method

 3 indicators radial-axial method

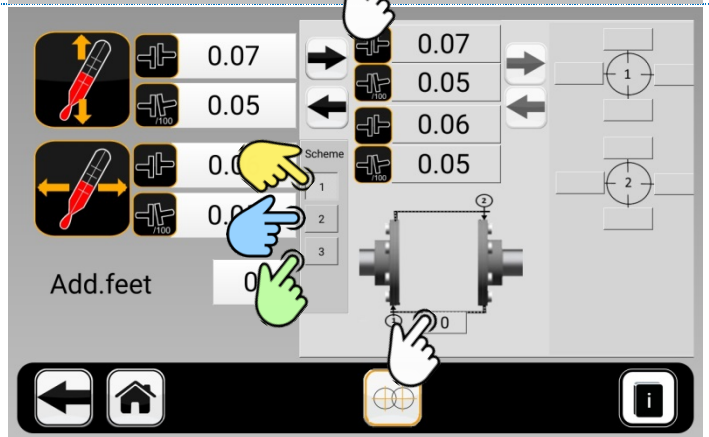

Tap the Right arrow icon to convert values to the indicator's readings.

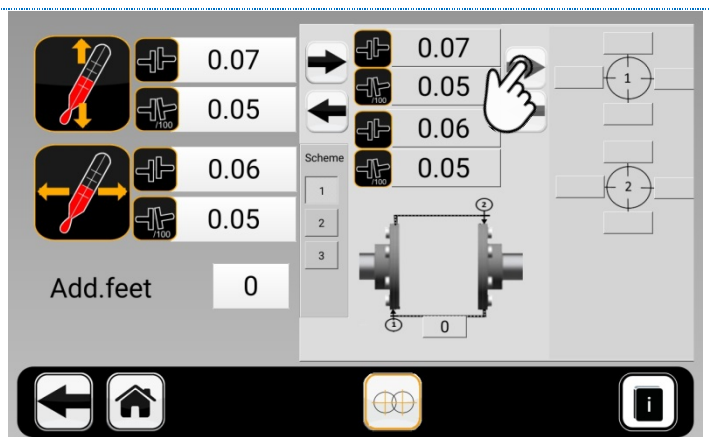

To convert from the indicator's readings, enter the values in the fields (the indicators are numbered according the image indicates the distance between the indicators).

The fields for indicator's values are located on the right side of the window.

Then tap the Left arrow icon.

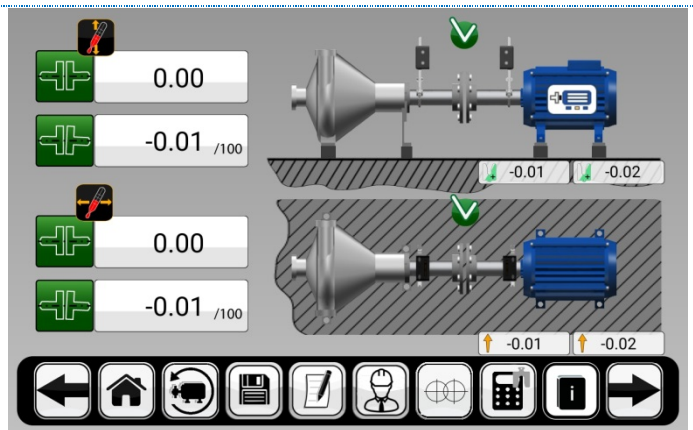
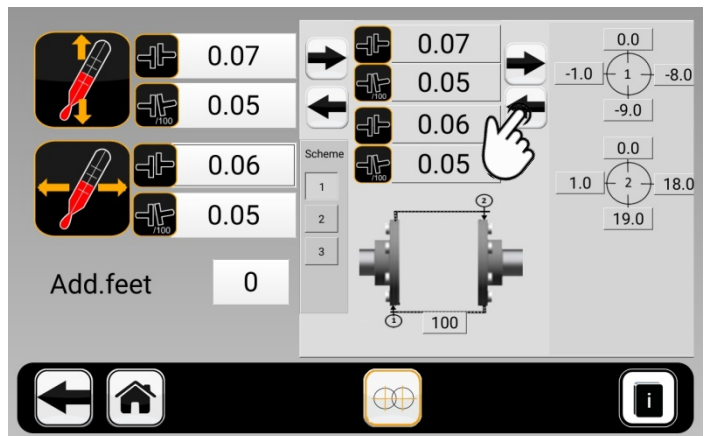
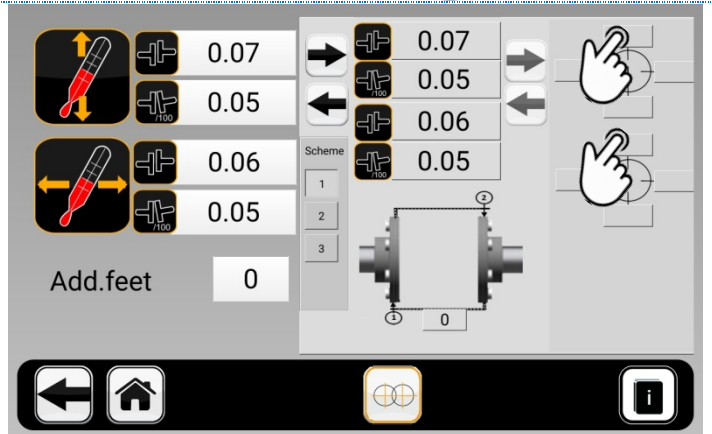

After control measurement, an icon



appears indicating that a temperature correction has been entered

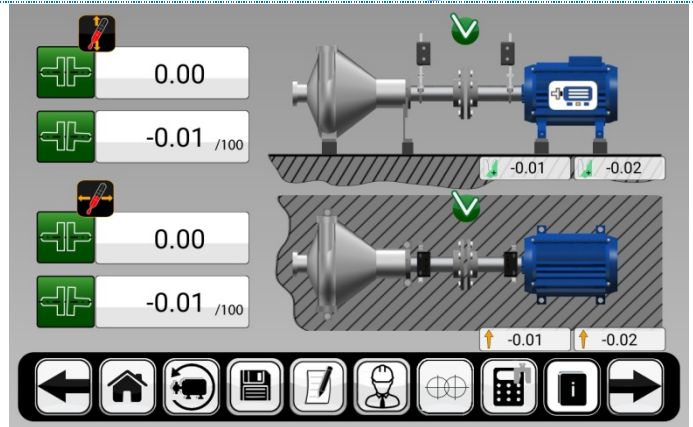

Hints:

1. When aligning the unit using the correction for thermal expansion, the corresponding sign will appear on the screen ;
2. In the case of alignment, a machine with space or cardan shafts, an icon appears on the Measurement Results screen, indicating that a temperature correction has been entered.
3. Information on thermal expansion will also be displayed in reports.

21.2. Intermediate feet calculator

In cases where the unit has more than two pairs of feet, it may be necessary to calculate the intermediate feet. In this case it is necessary to use the feature Intermediate feet calculator.

Tap the Settings icon



Tap the Intermediate Feet field and enter the number of Intermediate feet for the movable unit.
 If the total number of feet is 4, then the number of intermediate feet is considered to be 2 (The first and last pairs of feet are not considered).

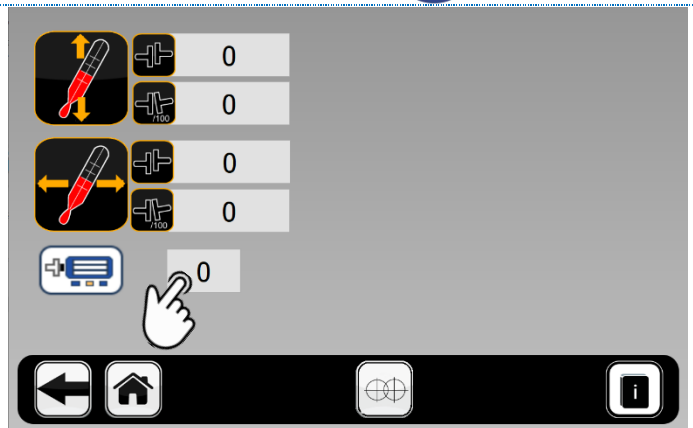

Tap the Feet Calculator icon.

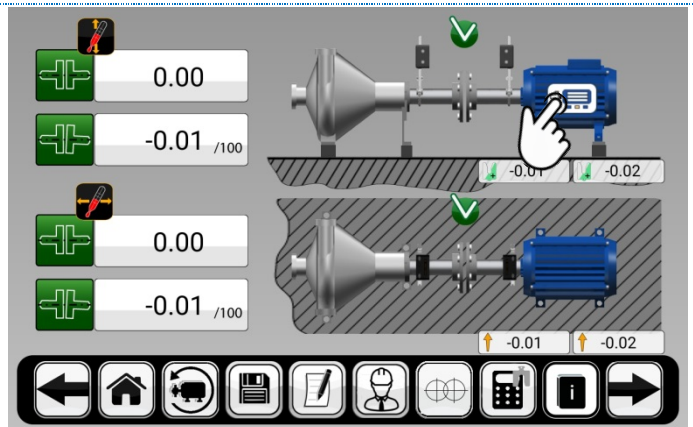

In the window that appears, select the pairs of feet that will be considered "base" (the distances to all intermediate pairs of supports will be measured from the "base"). Tap the field in the Distance column to enter data.

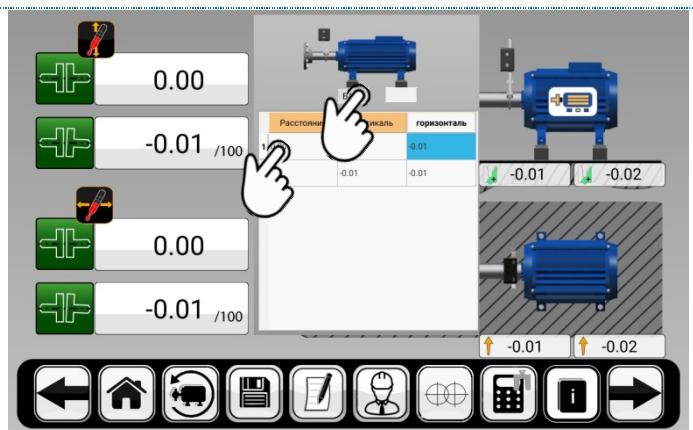

The Vertical and Horizontal columns will display the calculated values for intermediate pairs of feet.

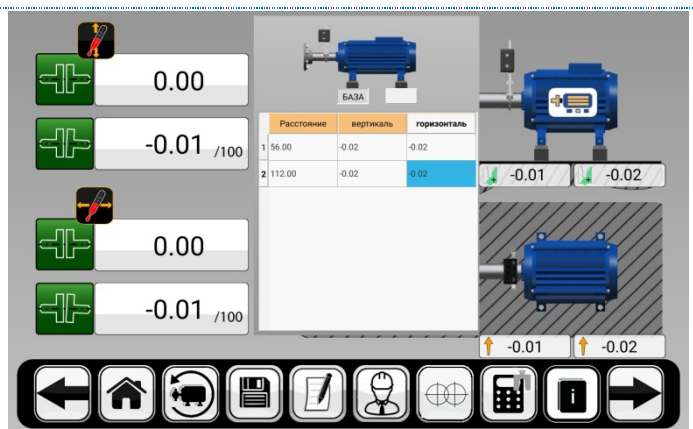

Hint:

1. When entering distances in the table, indicate the distance from the base pair of feet.

22. MACHINE TRAIN ALIGNMENT

Select the machine train alignment multi-coupling icon from the home page.

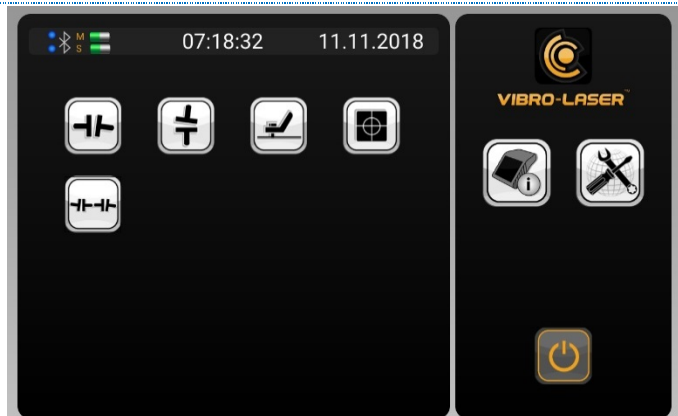

Select the gear icon on the main to choose the number of machines in the train.



Add the dimensions and thermal growth offsets if applicable for each component within the train as instructed.

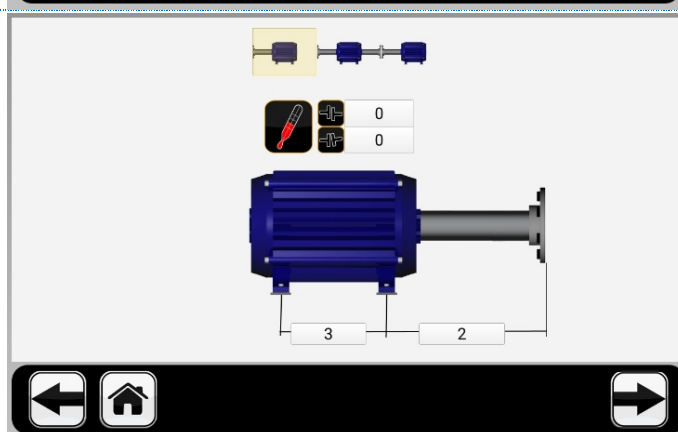

Select the first set of shafts you want to measure/alignment. Then select the tolerance applicable to this coupling and proceed with the applicable alignment steps as directed. This will display this machine/coupling current alignment status.

Refer to the horizontal machine alignment guidelines in order to select measurement mode and alignment setup.

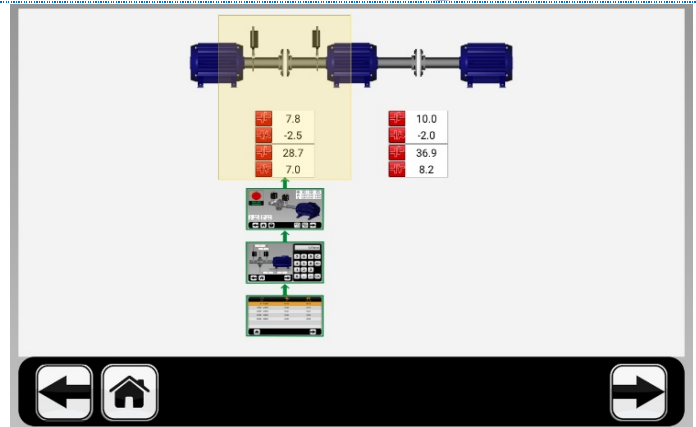

Move to the next coupling/machine and follow the same steps as identified above.

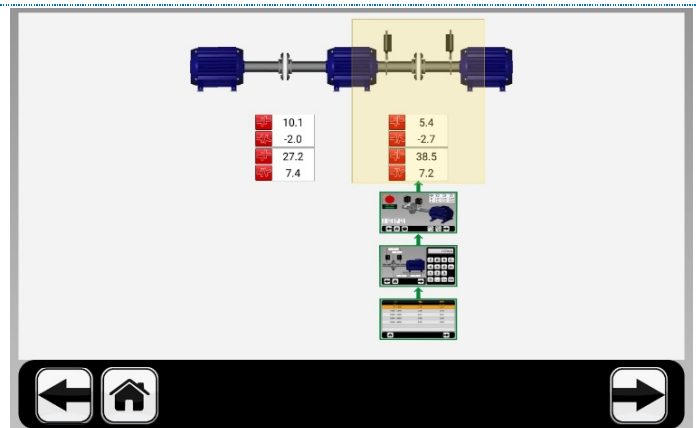

Upon completing the measurements for each coupling, you will then proceed to the current state alignment screen for the entire train.

Please note vertical view is on the top and horizontal view is on the bottom.

You can rescale by selecting the arrows on the left side of the screen.

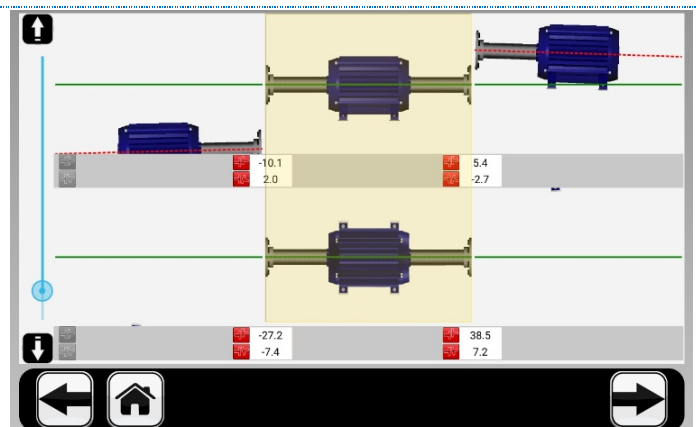

Next select the stationary machine per your requirement.

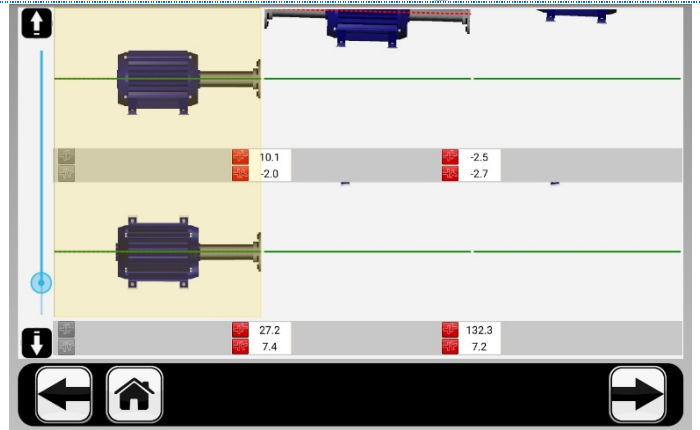

Move forward and you will be shown the shim and move requirements to be made based upon your stationary machine selection.

Recheck alignment as needed upon completing the shim and move requirements by going back to step 2 and remeasuring as required

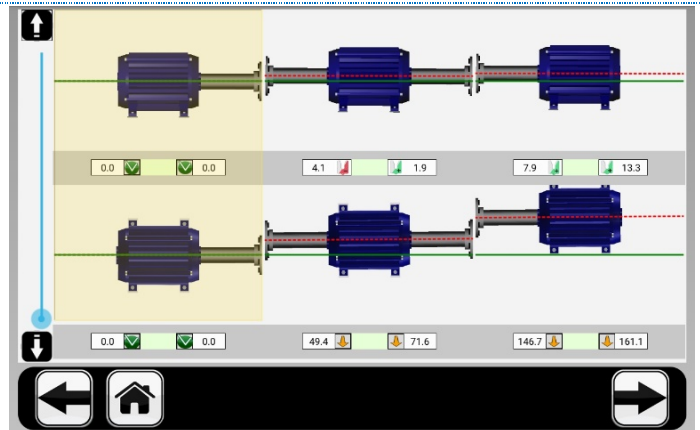

23. VERTICAL ALIGNMENT

23.1. Selection of tolerances

Tap the Vertical alignment icon

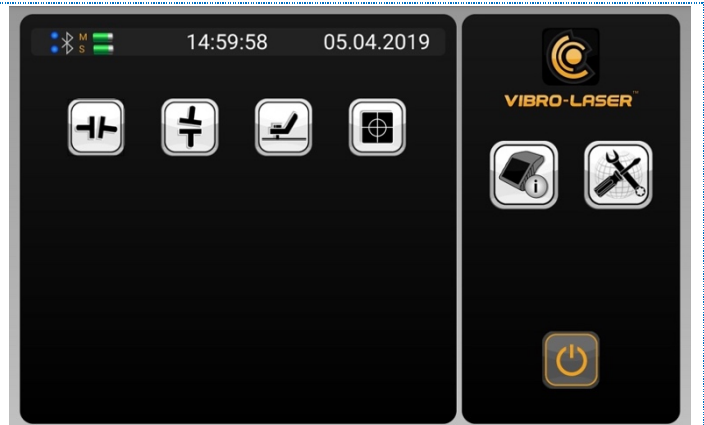

Tap the Eraser icon if you've taken measurements and want to start a new one
Tap the First screen image to start alignment



Hints:

If you want to continue the alignment process started earlier, click on one of the images of the windows highlighted in green.

Fill in the values in the windows with a “question”

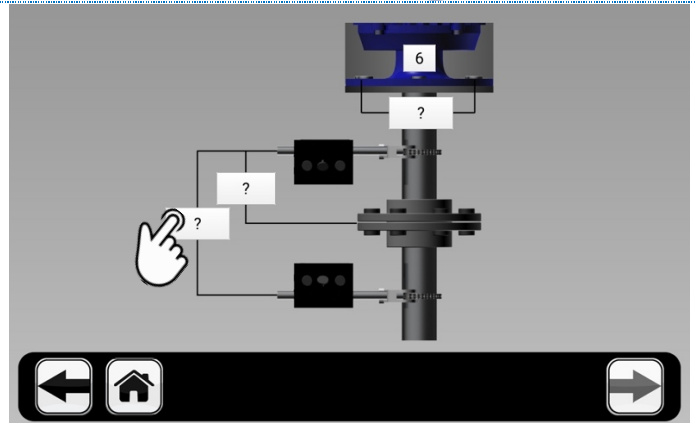

Hints:

The list contains a sequence of windows for entering values from top to bottom.

1. Indicate the number of bolts;
2. Distance between extreme bolt centers;
3. The distance between the centers of the racks M and S;
4. The distance between the center of the coupling and the center of the rack unit M.

Select Tolerances based on the speed of the vehicle or tap the plus icon to enter your tolerance values

Rpm	mm	mm /100 mm
00-1000	0.07	0.06
1000-2000	0.05	0.05
2000-3000	0.03	0.04
3000-4000	0.02	0.03
4000-5000	0.01	0.02
5000-6000	0.01	0.01

Hints:

1. To remove unnecessary tolerance values from the table, select them and tap the minus icon;
2. To return the original tolerance values, tap the Return Values icon (to the left of the Plus icon)

23.2. Measurement method 9-12-3

In the Vertical Alignment, the position of the machines is calculated on the basis of measurements in three positions of the shafts when they are rotated 180 °.

Set the measuring heads M and S to the first position so that they have the same angle of rotation and tap the take readings icon.

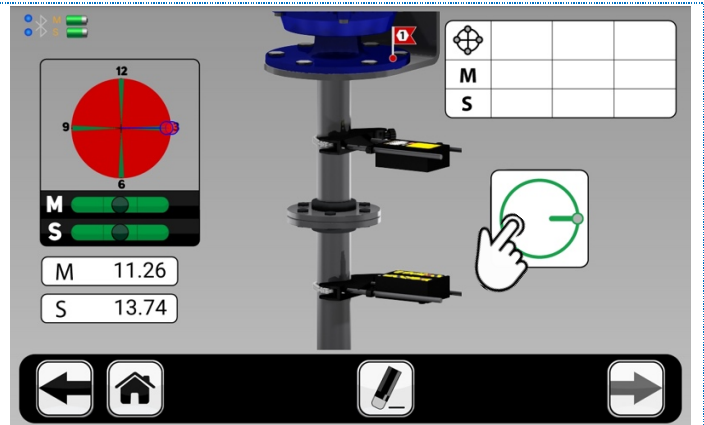

Hints:

1. Before taking measurements, control backlash;
2. Do not rotate the shafts with fixings of measuring units, measuring units or a chain;
3. Change the position of the units in one chosen direction (counterclockwise or clockwise);
4. Go to the measurement, click on the arrow icon.

Set the measuring units to the next position and tap the icon Take readings

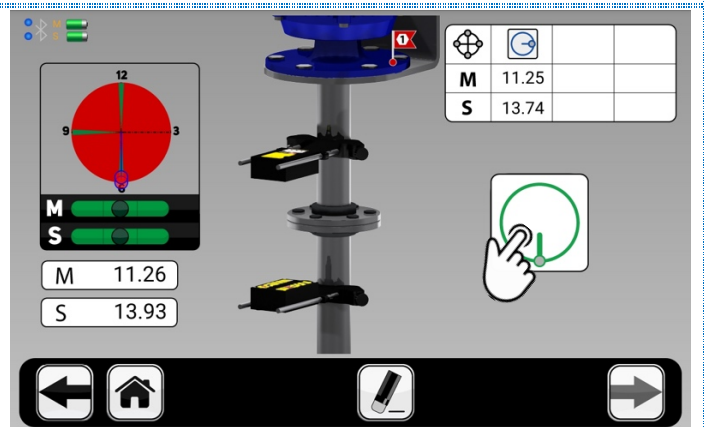

Hints:

1. Before taking measurements, control backlash;
2. Do not rotate the shafts with fixings of measuring units, measuring units or a chain;
3. Turn the measuring units by 90 degrees relative to the previous position;
4. Change the position of the units in one chosen direction (counterclockwise or clockwise);
5. In the table, in the upper right part of the screen, the results of the measurements are automatically displayed;
6. Go to the measurement, click on the arrow icon.

Set the measuring units to the last position and tap the icon Take readings.

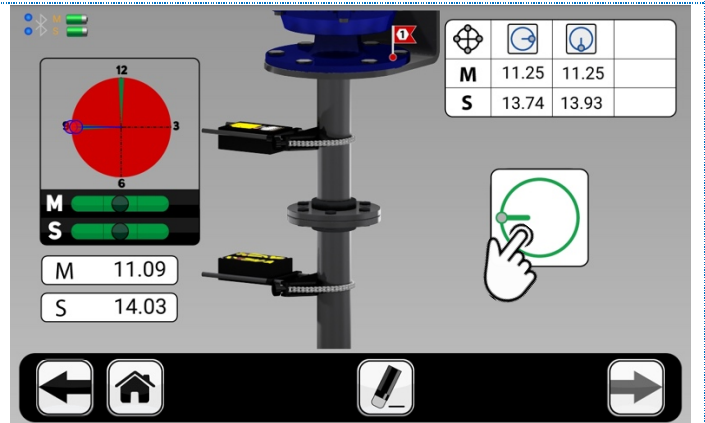

Hints:

1. Before taking measurements, control backlash;
2. Do not rotate the shafts with fixings of measuring units, measuring units or a chain;
3. Turn the measuring units by 90 degrees relative to the previous position;
4. Change the position of the units in one chosen direction (counterclockwise or clockwise);
5. In the table, in the upper right part of the screen, the results of the measurements are automatically displayed;

23.3. Measurement results

On the measurement results screen, coupling values are displayed in both directions.

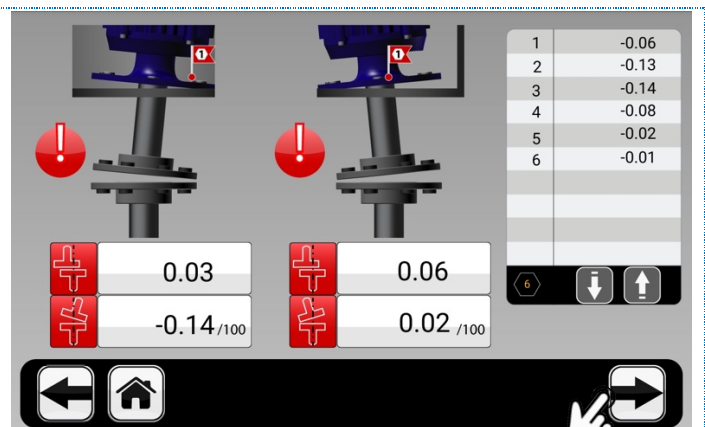

Hints:

1. The symbol to the left of the misalignment values indicates the direction of the kink and offset, and also indicates whether the values are within tolerances (red - values out of tolerance, yellow - value is in double tolerance, green - value in tolerance);
2. The table on the right shows the bolt numbers with the plate values required to eliminate the misalignment;
3. Go to the bolt measurement results by clicking on the arrow icon;

This screen clearly displays the values from the table on the results screen.

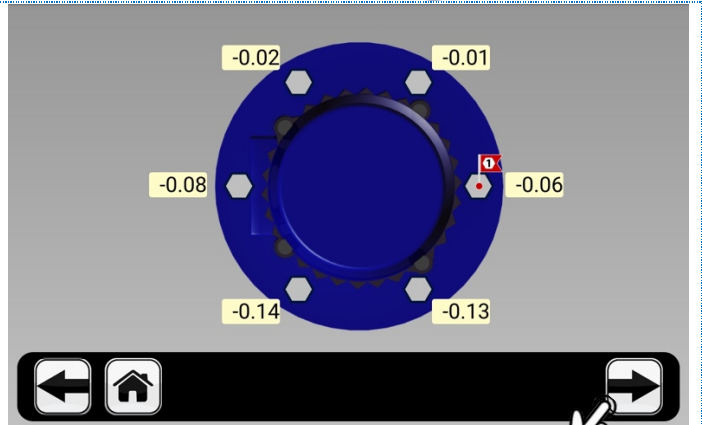

4. Put the shims of the required thickness under each bolt
5. Go to the control measurement mode by clicking on the arrow icon.
6. Take control measurements and complete the alignment process;
7. When carrying out control measurements, set the measuring units M and S to the same position as during the first measurement and repeat the measurement process using the method 9-12-3.

Measurement results

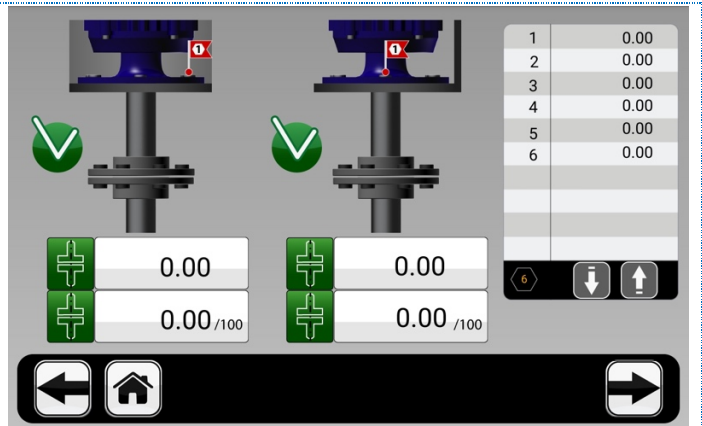

23.4. Saving reports

Tap the floppy icon to save the alignment results.

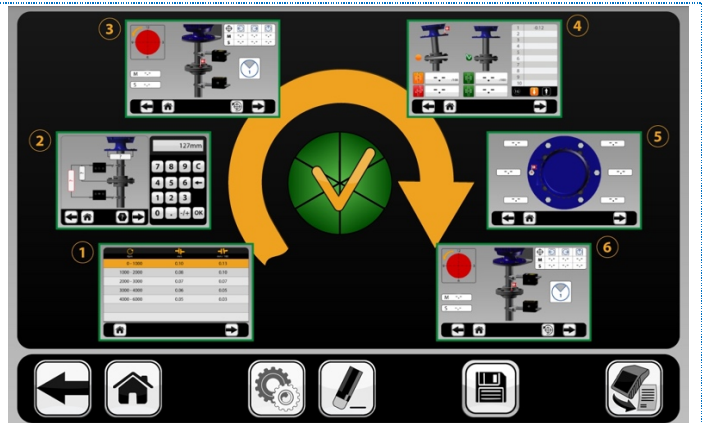

Using the keyboard, enter a name to save the result, press the “OK” button on the keyboard, and then tap the green icon to confirm the name.

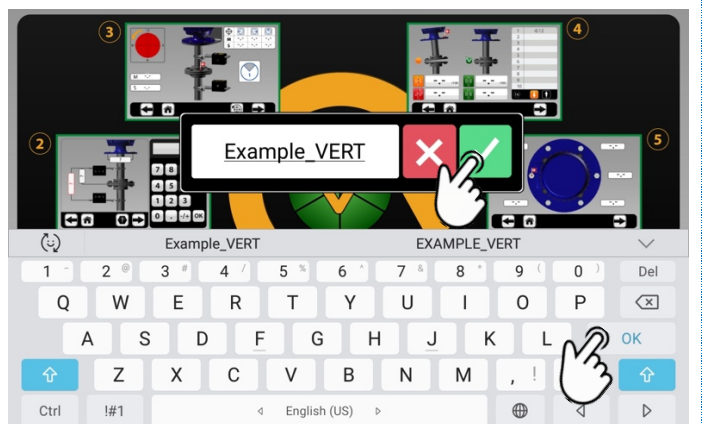

Tap the Measurement Reports icon to go to the list of all saved measurements.



Select one of the previously saved reports and tap the Save as PDF icon to save the report to the device.

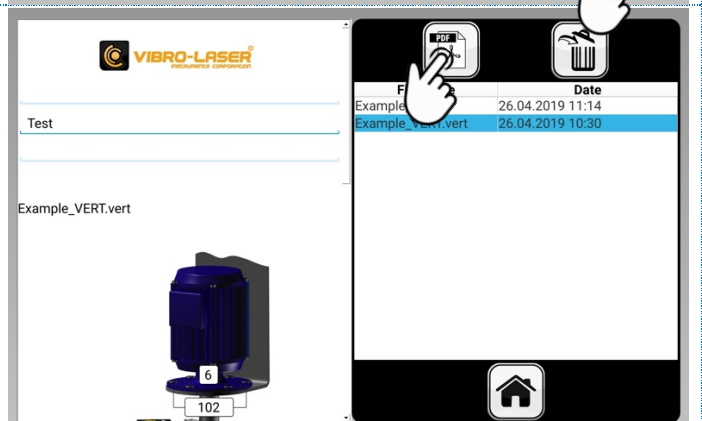

Hints:

1. All reports saved in PDF format can be found in the Documents folder on your iOS or Android devices;
2. If you do not save the report in PDF format, after deleting the VIBRO-LASER Alignment program, you will no longer be able to access the reports.

24. USEFUL INFORMATION

24.1. Download an application from Google Play Market and App Store

1. Account for Google Play Market

- 1.1. Create an account on gmail.com;
- 1.2. Open the Play Market application on your device and use the previously created account to enter the application;
- 1.3. In the search box, enter VIBRO-LASER Alignment (units firmware up to 3.7.3.) or VIBRO-LASER Pro (units firmware at least 3.7.4.) and click the Download button, then the application will be automatically installed on the device;
- 1.4. To update the application in the Play Market in the search box, enter the VIBRO-LASER Pro (units firmware at least 3.7.4.) and click the Update button.

2. Account for App Store

- 2.1. Create an account on gmail.com;
- 2.2. Go to apple.com and create an account using the previously created mail;
- 2.3. Open the App Store application on your device and use the previously created account to enter the application;
- 2.4. In the search box, enter VIBRO-LASER Alignment (units firmware up to 3.7.3.) or VIBRO-LASER (units firmware at least 3.7.4.) and click the Download button, then the application will be automatically installed on the device;
- 2.5. To update the application in the App Store in the search box, enter the VIBRO-LASER (units firmware at least 3.7.4.) and click the "Update" button.

24.2. Changes and additions

4.02.2020:

1. Added section 19.8. Multi-point method MultiSmart™
2. Added section 19.9. Uninterrupted method SmartSpin™

25.03.2020:

3. Changes to the subsection 19.1. Selection of tolerances and coupling type. Changed screens with the coupling types icon further added coupling type to the name of the subsection.

29.04.2020:

4. Changes to the section 15. Licensing. Changed screen – Enter the key. Deleted - Enter the key without spaces or dashes. The exception is VIBRO-LASER software on Windows platform, where you enter a dash when entering the key;

5. Added section 19.14. Shims Calculator;
6. Added section 19.15. Repeatability table;
7. Added section 19.20. Live move mode
8. Changes to the section 6. Charging measuring units.
Deleted - during measurements.
9. Changes to the section: 13. Preparing the system for work.
Added - Place the measuring units M and S between the racks so that the screw bar is under the measuring units. It is allowed to install the screw bar above the measuring units in the case when the units M and / or S are tightly adjacent to the base of the bracket.

02.10.2020.

10. Changes to the section 13: Picture with measuring unit has been changed.
11. Changes to subsections 19.12, 19.13, 19.14: added paragraph 6 about repetition of measurement
12. Changes to the subsection 19.16: Information about choosing previous measurements was taken away.
13. Added section 19.11: SMARTSHIFT
14. Added subsection 18.1: Selection of coupling type
15. Changes in section 18: Images was changed(actual in 2.2.00)
16. Changes in section 19: Images was changed(actual in 2.2.00)
17. Changes in section 16: Images was changed(actual in 2.2.00)
18. Added subsection 16.5: System language
19. Changes to the subsections 19.17, 19.18, 19.19, 19.20, 19.21: The last paragraph was changed.

10.12.2020.

20. Changes to the section 16.2. First 2 paragraphs was changed
21. Added subsection 19.8: Inclinator off measurement
22. Changes to the section 19.9: Added description and Images was changed (actual in 2.2.00)
23. Added subsection 19.8: Indicator conversion calculator
24. Added subsection 19.23: Live alignment without using an Inclinator
25. Changes to the section 18.1: Added description and Images was changed (actual in 2.2.00)
26. Added subsection 21.2. Intermediate feet calculator

13.05.2021.

27. Changes to the section 24.1. The name of App was changed

21.07.2021

28. Changes to the section 24.1. The name of App for Google Play Market was changed